

# **E N E R G Y C L I M A T E B U I L D I N G S**

An Introduction to Designing Future-Proof Buildings  
in New Zealand and the tropical Pacific

HUGH BYRD

# CONTENTS

## Introduction

## Energy Systems in New Zealand

- Energy and Buildings
- The Impact of Peak Oil on New Zealand
- Bio-diesel to Relace Oil?
- Peak Gas
- Peak Hydro
- Nuclear Power
- Coal
- Geothermal
- Windpower

## Climate Change in New Zealand

- Increased Temperatures
- The Impact on Buildings
- Carbon emissions due to buildings
- The Problem of Air-conditioning
- The Problem of Water

## Designing Buildings for the Future Climate

- The Environmental Control System in Buildings
- A Theoretical Model of the Environmental Control System in Buildings
- Designing with Climate
- Designing for a Changing Climate

## Passive Solar Energy in the Visible Spectrum

- Daylighting as an almost free energy source
- The Distribution of Daylight in a Room
- Uniformity of Light as a Means to Save Energy
- Techniques for the Uniform Distribution of Daylight
- Optimising the Size of a Window
- Types of Glass and their Effects on Energy Use
- Optimising Energy Savings from Daylight
- Views from Windows

## Low Energy Artificial Lighting

- Reducing Energy Consumption of Artificial Lighting
- Strategies for Low Energy Lighting Systems
- Lighting Requirements
- Types of Lamps and Lamp Efficiencies
- Energy Efficient Layout of Lighting Systems in Working Environments
- Switching Arrangements

## Shading Buildings

- Passive Methods to Avoid Overheating
- Shading to Avoid Air-conditioning
- Tracking the Sun throughout the Day and Year
- Blinds to Intercept Solar Radiation
- General principles of blind systems in hot climates.

Solar Control Glazing	Estimating the Energy Performance of Buildings
Cooling by Landscape	The Conflicting Requirements of the building
Methods of Cooling	Envelope
Measured Temperature Reductions	Balancing the Energy Flows Through the Building
Green Roofs	Fabric.
Cooling by Natural Ventilation	Daylighting
The Problem of Air-Conditioning	Heat Loss
Natural Ventilation as an Alternative to Air-	Overheating
Conditioning	Optimising the Building Envelope
The Basics of Natural Ventilation	Integrating Renewable Energy into Buildings
Single Sided Ventilation	Electricity from Photovoltaics and Wind
Double Sided Ventilation	Turbines
Stack Ventilation	Photovoltaics
Chimney Ventilation	Designing PVs into Buildings
Atrium Ventilation	Integrated vs Independent
Double Skin Facades	Optimum Orientation and Tilt
Night-time Ventilation	Wind Turbines
Controlling Natural Ventilation	Types of Wind Turbines
Cooling with Thermal Mass	The problem of Storing Surplus Energy
Thermal Mass to Enhance Cooling	Smart Grids and Smart Meters
Thermal Mass within a Building	Designing for Tropical Climates
Mass and Night-time Ventilation	Solar geometry
Thermal Mass Outside a Building	Shading devices
Phase Change Materials	Natural ventilation
	Photovoltaics

# INTRODUCTION

It is only in the last 100 years that mankind has harnessed enough energy from, primarily, fossil fuels to be able to construct buildings that have been able to ignore the climate around them and exclude the natural environment from within them.

Energy has allowed architects to design buildings that can ignore natural ventilation, daylight and the sun's energy by replacing it with an artificial environment that is air-conditioned, humidified and artificially lit.

This ability to use mechanical means to control the environment has allowed architects to freely experiment with the form, fabric and materials of a building in the knowledge that, however poorly the building envelope performs, the internal environment of a building can always be remedied by using more energy for cooling, heating or lighting.

One of the first examples of this is Mies van de Rohe's glass skyscraper project in Berlin in 1919. (Figure 1). While this design has a significant amount of natural light around the perimeter, it relies on artificial ventilation, heating and cooling systems in order to maintain a habitable environment internally. By burning energy in some remote power station, the



**Mies van de Rohe 1919, Glass Skyscraper Project.**

*"less is more" has become a bad joke since the lesser characteristics of the building envelope have resulted in more energy consumption.*

building can operate both day and night and remain reasonably comfortable so long as this umbilical link to the supply of energy can be maintained.

This architectural style, which has since been so crudely copied in cities throughout the world from hot deserts to the Arctic Circle, ignores protection from or harnessing of the natural environment and consumes extravagant amounts of energy in the process. It is an architecture that disproportionately consumes our limited natural resources and excessively contributes to global warming.

This style of highly-glazed, lightweight, poorly insulated building with no consideration to the position of the sun or prevailing winds has kept building scientists employed for decades. The problems that this style of building caused have been analysed, modelled and publicised. Problems such as 'sick building syndrome', overheating, glare and poor air quality are well documented (Roaf 2005). However, the remedies to these problems have come in the form of improved mechanical equipment that is dependent on yet more energy.

Mies van de Rohe's mantra was "less is more" with the implication that less of the building 'skin' was more aesthetically pleasing. Nearly a century later and with the hindsight of global warming and fossil

fuel depletion, the mantra has become a bad joke (Steadman 1975) since the lesser characteristics of the building envelope have resulted in more energy consumption and consequent emissions. It is time to rewrite the architectural history books and show 20th century architecture as a period in history when mankind designed buildings that burnt the earth's resources at a rate that deprived them for future generations .

If mankind could harness a never-ending supply of energy that does not harm the environment, this type of architecture may almost be justified. But the world has now reached a critical point in its depletion of fossil fuels and the profligate use of them has altered the earth's climate to the extent that it threatens mankind's survival.

The built environment is a large energy consumer. It varies from country to country, but across the globe about 40% of the world's annual energy supply is consumed by buildings and cities. Our preferred source of energy is oil and it is now reaching the stage when production cannot keep up with demand. We can no longer expect to maintain a 'business as usual' option and mankind faces a crisis. Our need for oil in the economy is not dissimilar to the human body's need for water; a small loss in supply has a disastrous effect. The human body contains over 80% water but it only needs to lose about 10% to bring on

death. The world's economies will not wait for oil to deplete before they collapse; the 'credit crunch' of 2008 provided a clear example of how a small change in a commodity can tip the system into recession.

Not only will economies be shaken by fossil fuel depletion but also building occupants who will suffer as first energy prices increase and, later, energy scarcity takes its toll. Buildings that are dependent on a supply of energy to maintain a habitable environment will face a difficult problem. Without a constant, uninterrupted supply of energy they will have to close down. Highly glazed buildings that rely on air-conditioning and have inadequate solar protection will become not only uninhabitable but also dangerous as temperatures rise beyond the body's tolerable limits.

Fossil fuel depletion provides enough reason alone to change our approach to building design. However, global climate change will also be a defining characteristic of the 21st century. Every country will have its own problems but New Zealand can expect a series of conspiring problems that will impact on building design.

The demand on electricity could grow exponentially as heat pumps and air conditioning are installed to combat the increases in temperature. The depletion of oil will result in an increase in electric cars and peak electric demand will shift from winter towards

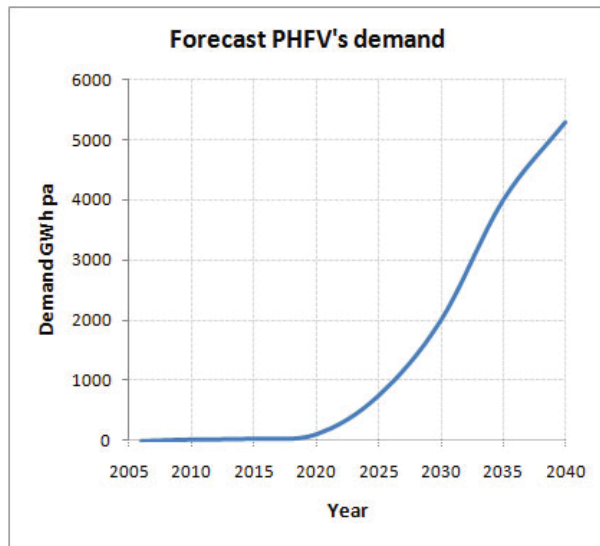

**Predicted Increase in Electric Car Use in New Zealand**

The depletion of oil will result in an increase in electric cars and peak electric demand will shift from winter towards summer. Source: Bruce Smith (2009)

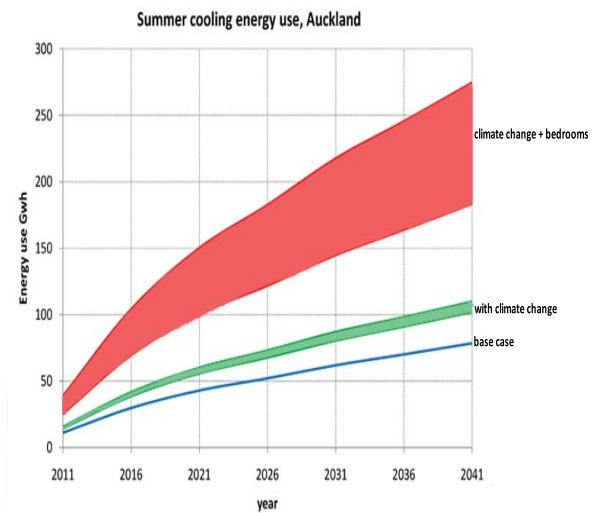

**Predicted increase in energy for cooling residential buildings in Auckland. Byrd & Segedin (2010)**

summer. This is the time when melt water from the glaciers feeds the hydroelectric lakes that have only a small capacity. Higher temperatures mean that the glaciers are retreating and their water storage capacity is reducing. Average rainfall will also reduce, causing a greater water demand for agriculture and a reduced amount for electricity generation.

In these circumstances, buildings that either do not rely on energy or rely on a relatively small amount have the ability to adapt not only to a world of scarce energy but also to a warmer world. Naturally ventilated and daylight buildings with appropriate solar control have a chance of being sustainable.

The term 'sustainable' is widely used, with even wider definitions, by those involved in the built environment. If nothing else, sustainable means something that can be maintained indefinitely. Buildings designed today that are dependent on an uninterrupted supply of electricity that relies to some extent on fossil fuel are unsustainable. The architecture of lightweight, highly glazed, poorly insulated and unprotected buildings results in buildings that are not resilient to a future of depleted resources, a changing climate and an ever increasing demand on energy.

Architecture must now move away from those designs and styles that pay little attention to the natural environment and move towards those that select aspects

of the environment in order to maintain control of the internal environment. These are designs that are characterised by a built form that maximises useful ambient energy, takes account of the sun's position and allow occupants to intervene in the control system.

New Zealand has historically lagged behind European countries in introducing higher standards for the environmental performance of buildings. For example, it introduced a Building Code requiring double glazing some 30 years after the UK and a rating tool for assessing the environmental credentials of buildings some 20 years behind. At the beginning of the second decade of the 21st century New Zealand is still building glass boxes and calling them 'sustainable'. There is at present a strange paradox where buildings can have a 'sustainability' rating of "best practice" and yet have a building envelope that is on the threshold of breaking the law (Building Code) (Byrd 2010).

This book is intended for building designers and provides a simple guide to the concepts that can produce designs that can make buildings sustainable. While many of the principles are universal, the issues of future energy supplies and climate change have been directly aimed at New Zealand. New Zealand is gifted with resources that can supply energy but it also faces an energy crisis. Architects have a pivotal role in mitigating the problem but, at the beginning of the

second decade of this century, much of the so-called sustainable architecture that is being built is neither prepared for climate change nor able to adapt to a low energy future.

Possibly the most significant cause for this has been the failure in architectural education in the latter half of the 20th Century and the beginning of the following century to resolve the conflict between Building Science and architectural design. It is generally considered that building science should be taught so that it can be integrated into the design process. This belief is an architectural version of the 'Emperor's new Clothes'.

The design process in architecture and the implementation of building science are not only incompatible but are cognitive processes that work in opposite directions. Architectural design is about generating form from concepts and composing a whole entity. Building Science is about taking an existing form and decomposing it into fragmented parts. Conventional Building Science cannot be applied during the design process; it can only be implemented as a check after the design is reasonably complete. At this stage it cannot influence the major environmental design decisions and is relegated to a fine-tuning device.

If Building Science is to influence architecture

beyond the 'fine-tuning' of a detailed design, it must influence early design decisions where the fundamental properties of the building's environmental performance are decided. At this stage of the design process, the designer has no place for a detailed simulation of a concept; instead the most powerful tools are a combination of a conceptual understanding of environmental performance and rules-of-thumb.

This book is concerned with the conceptual understanding of environmental performance and the chapters on environmental performance are concerned with rules-of-thumb. To many Building Scientists, rules-of-thumb tend to be seen as crude and inaccurate requiring detailed computational analysis at a later stage to validate a design.

The evidence is to the contrary; buildings that have been simulated to extreme lengths at the detailed design stage frequently fail to meet the predicted outcome. There can be no better example than the so called 'sustainable' buildings with LEED accreditation in the United States where studies have shown that a standard deviation between predicted and actual energy use is of the order of 50% (Turner & Frankel 2008).

On this basis, rules-of-thumb have a similar if not greater accuracy. However, the advantage that rules



-of-thumb have is that they can be used at the early design stages.

The only issue left is whether or not we are too late. New buildings will only constitute a small proportion of New Zealand's building stock as 'peak oil' and global warming kick-in. New buildings designed to be future-proofed will not have a significant impact on the country's energy demand. However, in an energy deprived future, every gesture counts. It is not only about energy but also about being able to maintain the use of buildings in order to sustain our social and economic needs.

There has been little research in New Zealand on contingency plans for peak oil. However, in 2005 The US Department of Energy commissioned a report into the risks and impact of 'peak oil' on America. The conclusion was:

"To avoid global economic collapse, we need to begin a mitigation crash program 20 years before peaking."

If this is correct, then New Zealand should also have started mitigation crash programs almost 20 years ago.

This book is a small contribution to this mitigation.

## REFERENCES

Smith, B (2009) "Electric Vehicles and generation development". NZ Electricity Commission. Conference on :The Impact of Electric Vehicles on the NZ Electricity System. <http://www.electricitycommission.govt.nz/pdfs/opdev/modelling/GPAs/presentations-29Feb08/electricvehicles.pdf>. Accessed July 2010

Byrd, H. & Segedin, E. (2010) New Directions for Research due to Climate Change in New Zealand. paper for the 2010 Australasian Housing Researchers' Conference, Auckland.

Roaf, S. (2005). Adapting Cities and Buildings for Climate Change. Architectural Press, Oxford.

Steadman, P. (1975) Energy, Environment and Building. Cambridge University Press. Cambridge

Byrd, H. (2010) 'Architectural Science vs. Green Buildings: issues for New Zealand'. Proceedings of the 44th ANZAScA Conference, Unitec, NZ

Turner, C. & Frankel, M. (2008) Energy Performance of LEED® for New Construction Buildings. New Buildings Institute, Vancouver for the US Green Building Council.

# ENERGY SYSTEMS IN NEW ZEALAND

## Energy and Buildings

One of the greatest challenges facing humanity in the 21st century is the depletion of fossil fuel resources. This chapter focuses on the depletion of fossil fuels both internationally and in particular New Zealand. This will give an idea of what the fuels of the future are likely to be and whether humanity can continue to consume energy at the current rate.

Readily available fossil fuels have allowed societies to increase affluence and productivity. However, the rate at which resources have been consumed in order to achieve this cannot be sustained by this planet and energy systems will need to change in order to use remaining resources more efficiently and exploit renewable energy.

This is particularly relevant to architecture since most of the buildings that stand today are the product of the last 100 years when energy supplies were perceived as being endless and uninterrupted. This has led to an architecture of profligacy where energy consumption of a building has not until very recently been of



**Figure 1.1**  
**Auckland University's Business School Building**

The highly glazed commercial buildings with no means of natural ventilation are totally dependent on an uninterrupted supply of electricity to maintain an air-conditioning system. Without cooling, these building types rapidly overheat and become not only uncomfortable but also unsafe and uninhabitable

consequence.

In most developed countries, buildings consume typically 40% of the total energy consumption and much of this is used for heating, lighting and cooling buildings. This figure is slightly lower in New Zealand for several reasons including a mild climate and a relatively small number of industrial buildings.

Almost all buildings use imported energy (energy not generated on site) to assist with controlling their internal environment and those where the design does not take appropriate account of the climate generally use more energy. Trends in architectural design have led to buildings that not only require significant amounts of energy to control their internal environment but

also buildings that are totally dependent on energy in order to remain functional.

For example, the highly glazed commercial buildings with no means of natural ventilation (Figure 1) are totally dependent on an uninterrupted supply of electricity to maintain an air-conditioning system. Without cooling, these building types rapidly overheat and become not only uncomfortable but also unsafe and uninhabitable. To remain in operational, these buildings must consume a large amount of energy to run the building's heating, cooling and lighting systems.

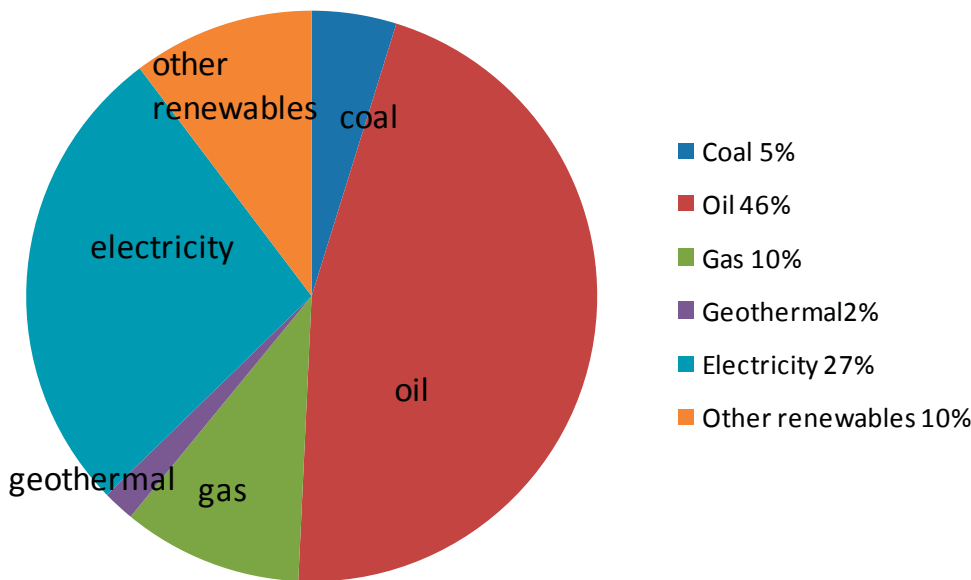

Figure 1.2  
New Zealand's Fuel  
Consumption

Source: (1) New Zealand Energy Data File, Ministry of Economic Development (2011)

This raises several issues concerning energy consumed by buildings. Is there adequate energy available for these buildings in the future? What impact will high energy consuming buildings have on energy demand and Carbon dioxide production? What impact will these buildings have on Climate Change and vice versa?

To answer these questions it is necessary to look at the current and future trends in energy production. Figure 1.2 illustrates the various sources of energy consumed in New Zealand. While there is scope for increased renewable energy production in NZ (Figure 1.3), the country is still dependent on almost half of its energy comes from imported oil. Oil is a fossil fuel that

has now almost reached its peak production (Figure 1.4). There will shortly be not enough 'easy to find' oil to satisfy demand.

The US, whose domestic oil supply peaked in the 1970's, have begun to make contingency plans. In a report (4) on peak oil commissioned by the US Department of Energy, the oil analyst Robert L. Hirsch concluded, "To avoid global economic collapse, we need to begin a mitigation crash program 20 years before peaking."

Secondly, almost 10% of New Zealand's energy comes from its own gas fields. These are past their peak production. (see Figure 1.6).

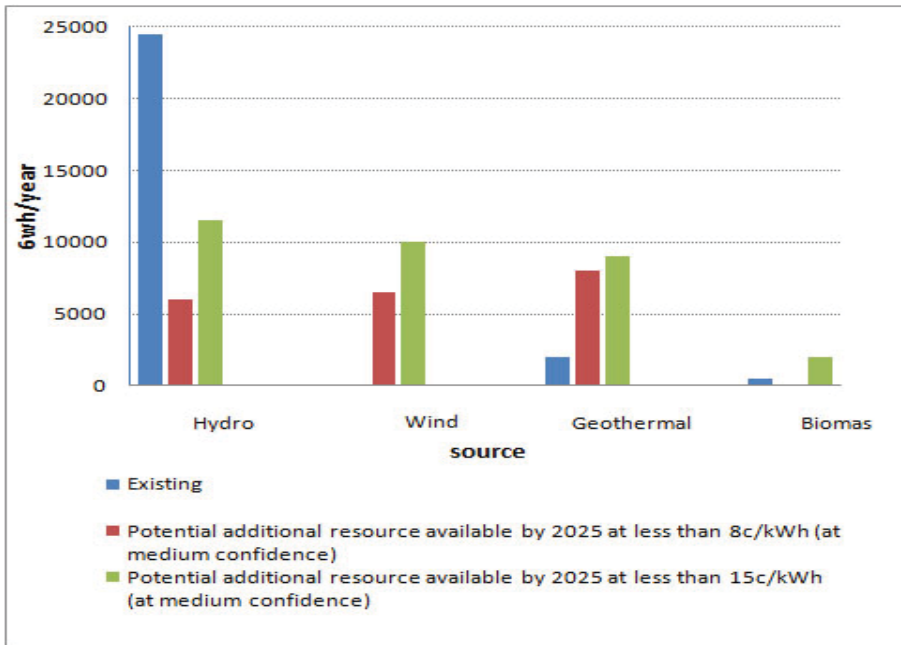

Figure 1.3  
New Zealand's potential  
Renewable Energy  
Resources  
New Zealand Energy Data  
File, Ministry of Economic  
Development

Thirdly, electricity is mostly produced from hydroelectric lakes. These lakes have a small capacity and rely on melt water from the snow and glaciers which act as a latent water supply. With global warming, glaciers are gradually melting which is providing additional water in the short term but, if the glaciers were to disappear, will result in a huge loss of water capacity for hydroelectricity. Global warming is likely to cause 'peak hydro'.

Coal is a dirty fuel to burn and there are already

policies in place to reduce the amount of coal used in thermal generators in order to reduce emissions. Geothermal energy contributes a relatively small amount of energy but there is scope to increase this a little.

Energy supplied from wind turbines is increasing and will become an important source of energy in the future but will not significantly replace fossil fuels. There is also some scope for biofuels.

These will all be discussed in more detail later in this

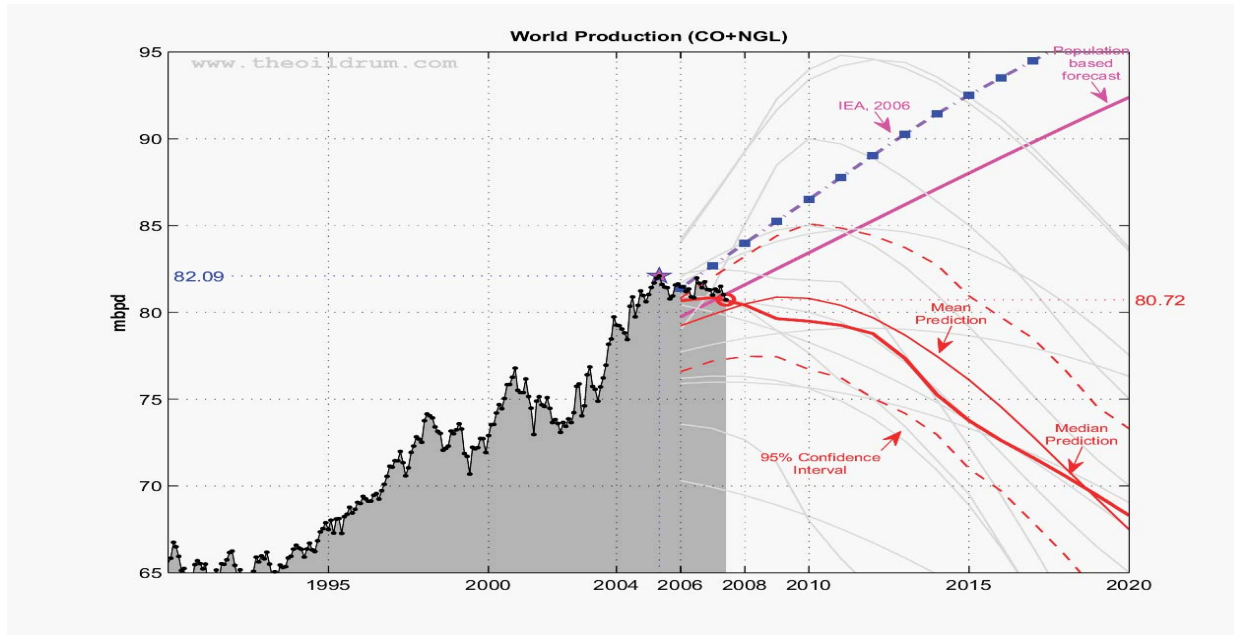

Figure 1.4

#### Predictions of Peak Oil' (source: ref 7)

In a report on peak oil commissioned by the US Department of Energy, the oil analyst Robert L. Hirsch concluded, "To avoid global economic collapse, we need to begin a mitigation crash program 20 years before peaking." If this is correct, and in view of the sudden change in mind of the IEA, the 'crash program' for New Zealand should have started 10 years ago.

chapter. However, it should be clear that New Zealand is facing a possible energy crisis in the near future.

### The Impact of Peak Oil on New Zealand.

The New Zealand Energy Strategy (3) long term view (p33) is for biodiesel and electricity to begin to replace fossil fuels. However, the forecast of the document is that overall energy consumption in the transport sector will peak within the next few years and then decline.

About 48% of New Zealand's energy consumption is

in the form of oil and, of this amount; 86% is used for transport. To sustain this level of oil supply while fossil fuels deplete is a huge task. The arguments for and against biodiesel continue but, despite the Royal Society's view (4) that there could be adequate domestic supplies of biofuel, there will always remain the question of whether we should be feeding people or cars.

Figure 1.5 summarises the NZ Energy Strategy for the supply of future fuels for transport. There are two important characteristics of the curves that need



greater scrutiny. The first is that the overall energy supply from all sources remains more or less constant over the next 40 years. The message this sends out is, 'nothing to worry about here as long as we don't consume more than we do now'. The graph is at least 10 years out in its timing. 'Peak oil' is upon us and we have no effective contingencies.

The second characteristic worthy of scrutiny is the extent to which the country relies on the graph's lilac coloured fuel: biodiesel. The Strategy has clearly identified this as the main fuel of the future. In 40 years time it comprises more than half of all the fuel for transport and even more than the amount of petrol we are currently consuming.

While biofuels are, in theory, sustainable they are not substantial. The total annual energy available from biota (animals and plants) on this planet is about 0.25% of the total annual amount of fossil fuels that we burn in one year (5). Another way of looking at this is that we would need 400 years of biofuels to replace one year of fossil fuel at our current consumption rate. The idea that the world can switch from fossil fuels to biofuels is a myth.

### Peak Gas

New Zealand's natural gas production has been dominated by the Maui Field. Considered a 'giant' when

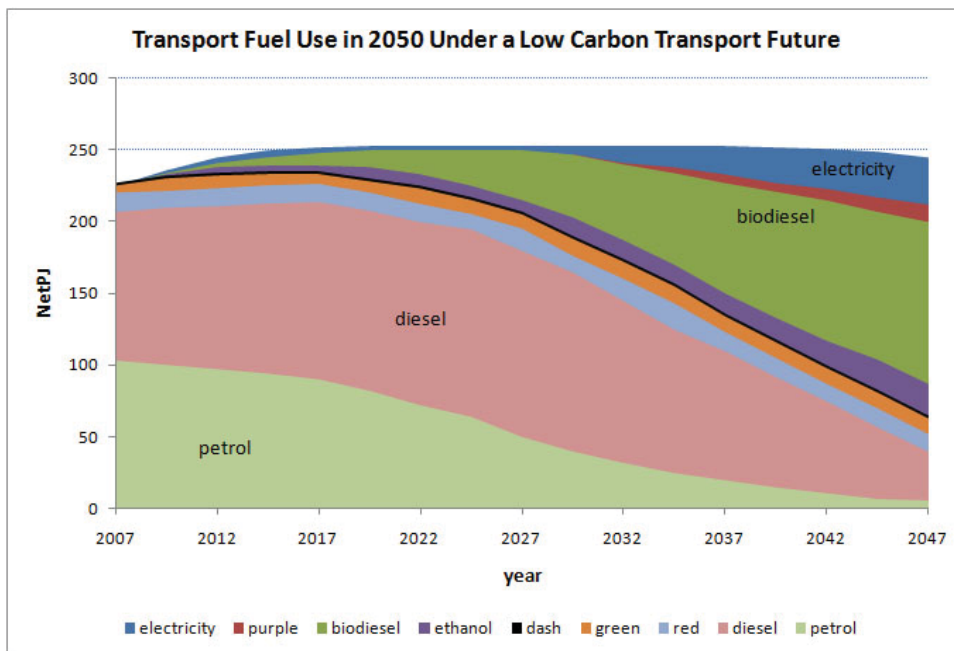

Figure 1.5  
New Zealand's Predicted  
Future Fuel Use for  
Transport.

We would need 400 years of biofuels to replace one year of fossil fuel at our current consumption rate. The idea that the world can switch from fossil fuels to biofuels is a myth.

Source: New Zealand Govt. (2007)

discovered in 1969, its reserves are now dwindling. Smaller gas fields have also been exploited and are at varying stages of production. However, the overall picture of gas production in New Zealand (Figure 1.6) indicates that it is beyond its 'peak'.

There is hope that there are other fields where there are economically viable gas reserves. In the meantime, the construction of the proposed gas-powered generators in Helensville have been put on hold due to lack of confidence in domestic gas production.

An alternative for New Zealand is to import liquid natural gas from the international market. However, this has implications on future energy security and cost.

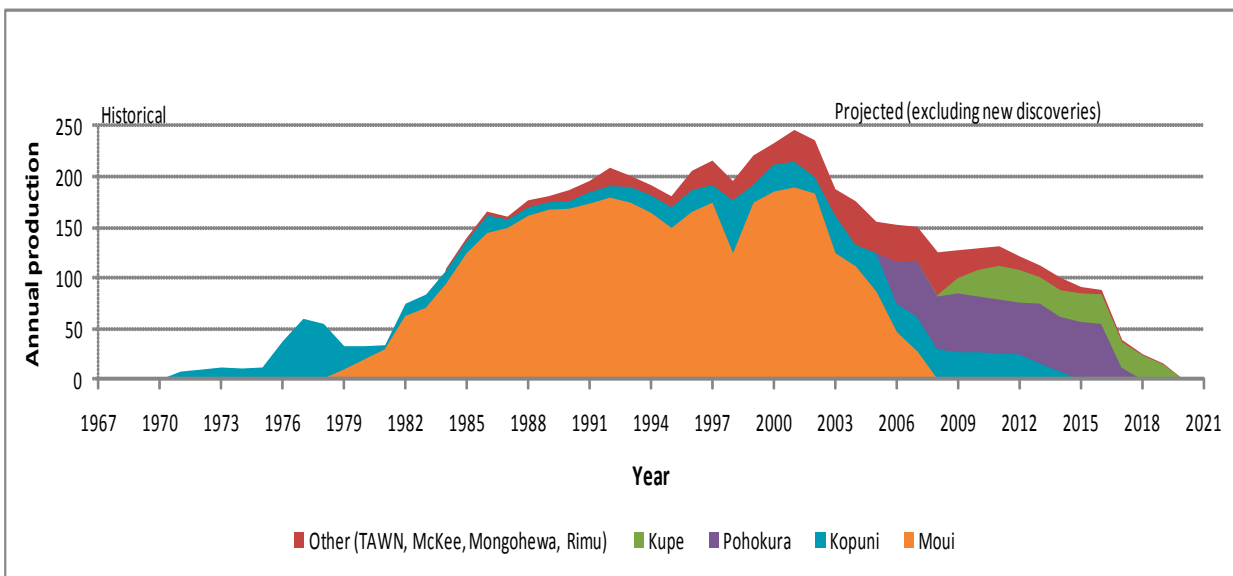

**Figure 1.6**  
Natural gas availability by field: New Zealand  
Source: New Zealand Energy Data File, Ministry of Economic Development



## Peak Hydro

The hydro industry has long formed the backbone of New Zealand's successful power sector. It has provided a relatively constant 60% of total electricity production since the 1930s and enabled the country to enjoy some of the lowest power tariffs in the world

The big fear is that an unusually severe drought would trigger power rationing and the vulnerability of the power sector to dry years is becoming increasingly apparent with the decline of the Maui gas reserves.

One of the biggest problems with New Zealand's existing

hydro schemes is the lack of water storage capacity. New Zealand's hydro schemes do not benefit from such large reservoir capacity and most have just a few months worth of storage (6). They are therefore more vulnerable to annual or even seasonal fluctuations in precipitation and snow melt. The variation in electricity production during the course of a year in the 1990s was around 20%.

Glaciers across the globe are continuing to melt so fast that many will disappear by the middle of this century according to the World Glacier Monitoring Service (WGMS). The WGMS records data for nearly 100 of the world's approximately 160,000 glaciers, including 30 "reference" glaciers, with data going back



Figure 1.7  
New Zealand's melting  
glaciers

to at least 1980.

New Zealand Glaciers have an estimated volume of about 53Km<sup>3</sup> and have been gradually decreasing in volume over the last century by about one quarter to one third (8).

More than half the water entering hydroelectric lakes comes from glacial water. However, global warming will have an impact on this. Predictions (9) of a 3°C temperature rise and 15% increase in precipitation indicated a significant decrease in snow accumulation resulting in increased flows of 40% in the winter and a 13% decrease in the summer.

With increased temperatures, the peak demand for electricity will shift towards summer rather than winter. There will also be an increased demand for water for irrigation during the summer. This will reduce the ability of the hydroelectric power sector to provide an unfluctuating supply and could result in significant reduction in the hydroelectricity supply in the future.

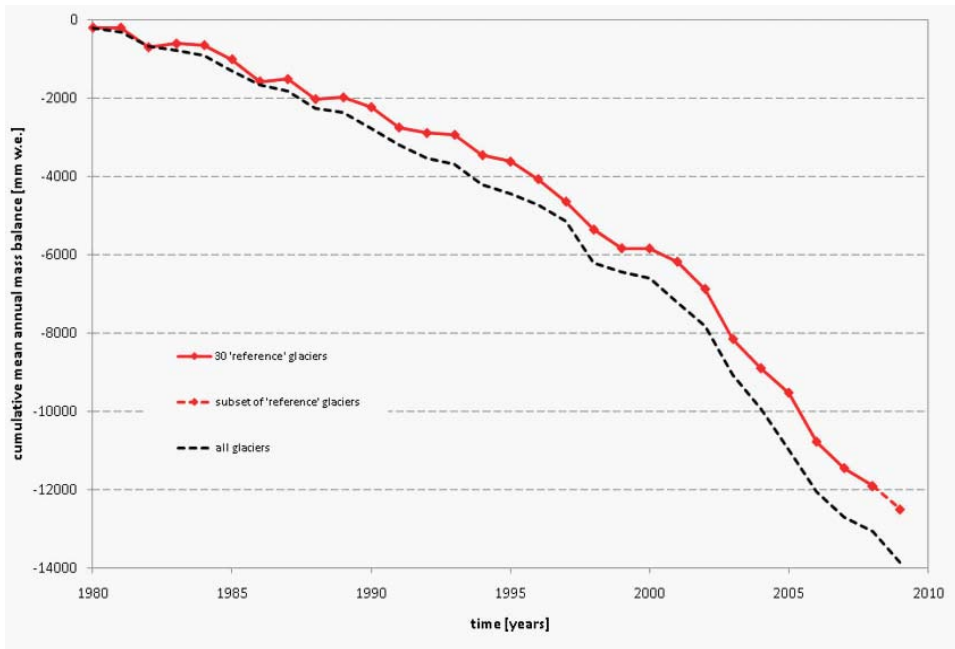

Figure 1.8  
Decline of New Zealand's  
Glaciers  
Source: World Glacier  
Monitoring Service [http://  
www.wgms.ch/mbb/sum09.  
html](http://www.wgms.ch/mbb/sum09.html)

## Nuclear Power

New Zealand very nearly adopted nuclear power in the late 1960s (10). The 1968 Power Planning Report recommended a 250MW nuclear power station to be operational by 1977 with 3 further reactors to follow at intervals and a site was selected north of Auckland. Experts were sent from the UK and plans drawn up. However, by 1970 it became evident that the Maui gas field had substantial quantities of natural gas and the proposed nuclear power plants were replaced by a 1000 MW gas-fired station.

In the late 1970s the forecast growth in demand had increased again and nuclear power was once again on the agenda. However, the political climate was changing and the nuclear testing by France in the Mururoa atoll, the meltdown of the 3 Mile Island nuclear plant in America in 1979, followed by New Zealand's Nuclear Free Zone, Disarmament, and Arms Control Act in 1987 effectively ended nuclear power in New Zealand.

In the second decade of the 21st Century, we now face the problem of both fossil fuel depletion and global warming. Nuclear power would seem to be an attractive alternative and it is just a matter of time before it is back on the agenda again. So it is worth reviewing the issues for and against it to see whether it may provide the answer to all the energy and

climate problems.

There are issues of safety, security and proliferation to consider as well as the moral issue that it may be wrong to commit future generations to the consequences of fission power when there currently exists no way of safely isolating the wastes for the indefinite future.

There is also the issue of Uranium depletion. In 1990 the UK Atomic Energy Authority estimated that world Uranium supplies, that could be extracted at a reasonable cost, would only last about 45 years. It could be argued that more reserves will be discovered and that improved technology will increase the efficiency of reactors. However, if there is a worldwide increase in nuclear power in response to global warming, higher-grade ore will become scarce and the lower grade ore could become uneconomic to recover. This is called 'the point of futility' where the energy required to process the fuel becomes greater than the energy that can be generated from it.

There are also issues of cost. A nuclear power plant takes about 10 years to construct and commission which results in high initial capital costs. These costs need to be recovered in the sale of electricity and for every unit of energy produced about 2/3rds of the cost is taken up by the capital charges. In a country

where most electrical energy is derived from renewable energy sources, the high investment costs and slow rate of payback make it unattractive economically, especially as the life of a reactor is only about 40 years.

Then there is the cost of decommissioning of a power station that can take about 60 years. For example, in the mid-1990s, the cost of decommissioning Sizewell C plant in the UK was estimated at \$1000 million NZ dollars equivalent. It can be difficult to envisage how a private company could maintain a commitment to a plant over a one hundred year period when it is only productive for 40 years.

## Coal

Coal is New Zealand's main indigenous fuel with significant reserves of high quality coal in both the Waikato region and the South Island's west coast.

Coal is used principally in industry and in electricity production. Almost 40% of coal used domestically was burnt in the Huntly power station. With gas supplies dwindling and dry winters reducing the amount of water needed for hydroelectricity, coal has been a useful source of energy to supplement the country's fuel mix.

However, coal is not a clean fuel to burn and has caused significant controversy both in New Zealand

	Natural Gas	Oil	Coal
<b>Carbon dioxide</b>	14,000	19,000	24,000
<b>Methane</b>	3.7	3	20
<b>Sulphur dioxide</b>	1	400	840
<b>Black smoke</b>	0	15	55
<b>Nitrogen oxides</b>	55	100	230
<b>Volatile organic compounds</b>	5	2	18
<b>Carbon monoxide</b>	7	8	210

**Figure 1.9**  
**Emission Factors of Fossil Fuels**

As gas and oil deplete and with the possibility of a decline in hydroelectricity, New Zealand will be forced to reconsider burning more coal. The promise of new technologies that significantly sequester Carbon has yet to be fulfilled.

source: Dept of Trade & Industry (2001) UK Energy Statistics, Annex B; Energy & Environment

and abroad. Figure 1.9 is a comparison of the emissions from natural gas, oil and coal. The difference in emissions between the fuels is staggering.

The Resource Consent for Huntly expires in 2013 and the equipment is reaching the end of its design life. It is expected that it will only be used as a reserve during dry years.

Research continues for a clean method of extracting energy from coal. A promising method is to manufacture Hydrogen from coal but this would still produce Carbon dioxide.

While the use of coal to produce electricity is declining at present for environmental reasons, its future use is uncertain. With the depletion of gas, both domestically and internationally, and with the possible decline of hydroelectricity New Zealand will be faced with a dilemma of whether to burn more coal to provide for the shortfall in electricity even if that means higher emissions.

### Geothermal

Geothermal energy is expected to increase significantly in the next decade with a number of large-scale projects announced, including Mighty River Power's 132 MW Nga Awa Purua plant and Contact Energy's 220 MW Te Mihi project.

In 2008 65% of New Zealand's electricity generation came from renewable sources but less than 10% came from geothermal energy. It is an important part of New Zealand's fuel mix but will have little impact on the future energy requirements.

### Wind Power

In 2010 wind power in New Zealand provided about 3% of the electricity generated within the country. The potential for wind power is enormous, and this is illustrated in Figure 1.10, but it has two major limiting factors.

1) There are many proposed wind farms but several of their consents under the RMA are being declined because of objections generally for reasons of appearance or noise.

2) Energy sources that cannot easily be stored, such as wind power, do not provide a secure source of electricity to the grid. If the wind stops, then the electricity stops. This limits the extent to which they can be relied upon. There is a general rule of thumb that no more than 20% of a country's supply should be from such sources.

### References

1. Ministry of Economic Development (2011) New Zealand Energy Data File. <http://www.med.govt.nz/sectors-industries/energy/pdf-docs-library/energy-data->

## Wind

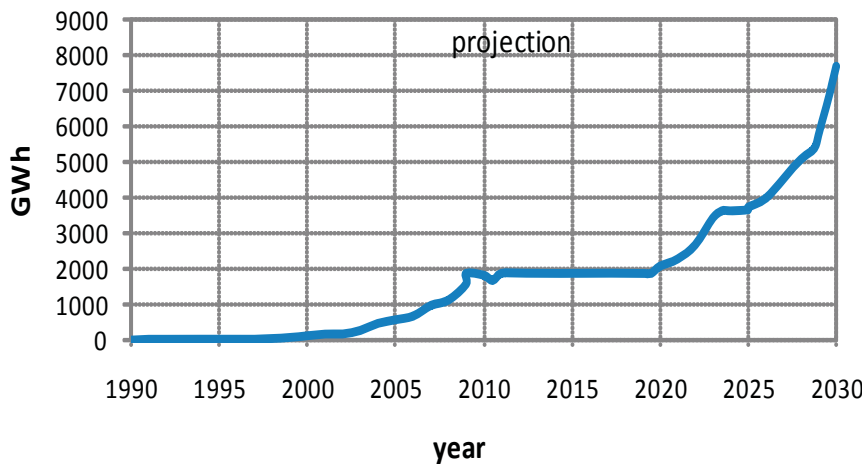

Figure 1.10  
Current and projected energy available from wind power in New Zealand

The potential for wind power is enormous but it is limited by concerns on the visual environment of rural areas. It is difficult to store energy produced by the wind and it is an insecure source should the wind stop blowing.

Source

<http://www.med.govt.nz/templates/>

and-modelling/energydatafile-2011.pdf

2. Hirsch et al (2005) Peaking of World Oil Production: Impacts, Mitigation and Risk Management. [www.netl.doe.gov/publications/others/pdf/Oil\\_Peaking\\_NETL.pdf](http://www.netl.doe.gov/publications/others/pdf/Oil_Peaking_NETL.pdf). Accessed Jan 2012

3. New Zealand Government (2007) New Zealand Energy Strategy to 2050. Ministry of Economic Development.

4. 2020: Energy Opportunities Report of the Energy Panel of The Royal Society of New Zealand (August 2006)

5. Jeffrey S. Dukes, 2003. Burning Buried Sunshine: Human Consumption Of Ancient Solar Energy. *Climatic Change* 61: 31-44.

6. Editorial, International water power and dam construction (2006) "Hydro in the Mix in New

Zealand". <http://www.waterpowermagazine.com/story.asp?sectionCode=166&storyCode=2039414>

7. [www.theoil Drum.com](http://www.theoil Drum.com)

8. World Glacier Monitoring Service (2009). 'Glacier Mass Balance Data 2008 &2009'. [www.wgms.ch/mbb/sum09.html](http://www.wgms.ch/mbb/sum09.html) accessed July 2010.

9. NIWA. Climate Change Scenarios for New Zealand. <http://www.niwa.co.nz/our-science/climate/information-and-resources/clivar/scenarios>. Accessed Jan 2012

10. Priestly, R. (2010) Nuclear Power: How Close We Came. <http://www.contrafedpublishing.co.nz/Energy+NZ/Vol.4+No.5+September-October+2010/Nuclear+power+How+close+we+came.html>

# CLIMATE CHANGE IN NEW ZEALAND

## Increased temperatures

Climate change will have an impact in many different ways in New Zealand including the severity of the climate, a rise in sea level, increased glacier melting, reduced snowfall, increased intensity of storms and changes in the intensity and distribution of rainfall.

All these will effect the built environment in different ways. However, the most significant overall impact will be the increase in average temperatures. Figure 2.1 indicates the predicted changes in temperature in New Zealand.

New Zealand's National Institute for Water and Atmospheric research (NIWA) (1) predicts that most of New Zealand will exceed an average 2°C temperature rise towards the end of this Century and that averages temperatures may rise by 1°C by 2030. As NIWA point out, it is very difficult to model this as assumptions need to be made about international policies, economic growth, availability of energy and other factors. Figure 2.1 is the “downscaled projections of mean temperature changes”. Different models produce different results and NIWA have modelled on 6 different emissions scenarios. The overall results were: “Averaging over all models and all 6 illustrative emissions scenarios

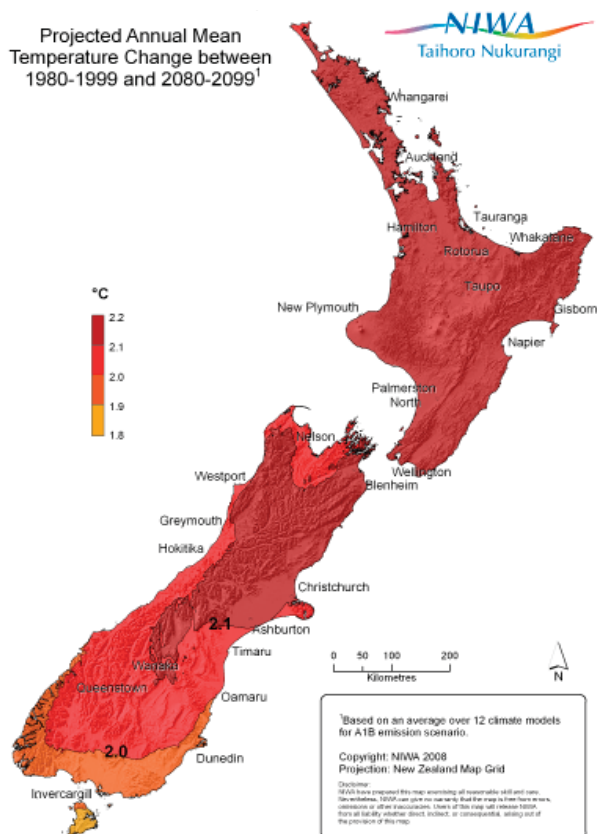

Figure 2.1  
Downscaled projection of mean temperatures in New Zealand.

“Averaging ..... emissions scenarios gives a New Zealand-average warming of 0.2–2.0°C by 2040 and 0.7–5.1°C by 2090”.

Source: <http://www.niwa.co.nz/our-science/climate/information-and-resources/clivar/scenarios>

gives a New Zealand-average warming of 0.2–2.0°C by 2040 and 0.7–5.1°C by 2090”.

### Impact on Buildings

The impact this will have on buildings in terms of energy will be twofold:

1) an insecure supply of electricity due to a combination of less melt water reserves in the glaciers and a potential shift in peak electric demand to the summer. Summer electricity supplies rely on melt water from glaciers to feed the hydroelectric lakes and rivers. Global warming is rapidly melting New Zealand’s glaciers (2) and this will result in less water reserves within the lakes. (This is discussed in ‘Peak Hydro’ in the Energy Systems Chapter).

2) buildings that have not been designed to control peak temperatures by passive means will require more energy for cooling systems that rely on electricity.

Existing Building Codes in New Zealand have evolved from and focus upon the energy consumed due to heat loss from buildings. Predictions of the impact of climate change (NIWA) have indicated average temperature increases across the country. The implication of this is that, in warmer areas of the country, there will be a greater cooling load and, in cooler parts of the country, a reduced heating load.

This is likely to result in a shift in peak electricity demand in the country from winter to summer. Figure 2.2 indicates that there has been a general trend over the last 50 years of a reduction in heating load of buildings (HDD) and an increase in cooling load (CDD). Extrapolating the data, it would indicate that energy required for cooling will exceed that for heating in about the year 2040. However, it is likely to be considerably sooner for two reasons;

1) Global warming has been accelerating.

2) The graph assumes that cooling load is directly proportional to temperature. In practice, people’s demand for thermal comfort depends not only on external temperatures but also on their expectations and ability to acclimatise. Air-conditioning delays the ability to adapt to warmer temperatures.

### Carbon emissions due to buildings.

The single largest producer of Carbon in the built environment is in the production of electricity by fossil fuels for heating, cooling and lighting buildings. In 2010, over 25% of electricity production was generated by coal and gas. However, this accounts for almost 90% of Carbon emissions.

As air-conditioning loads increase, they tend to produce a peak demand of electricity in the hottest hours of



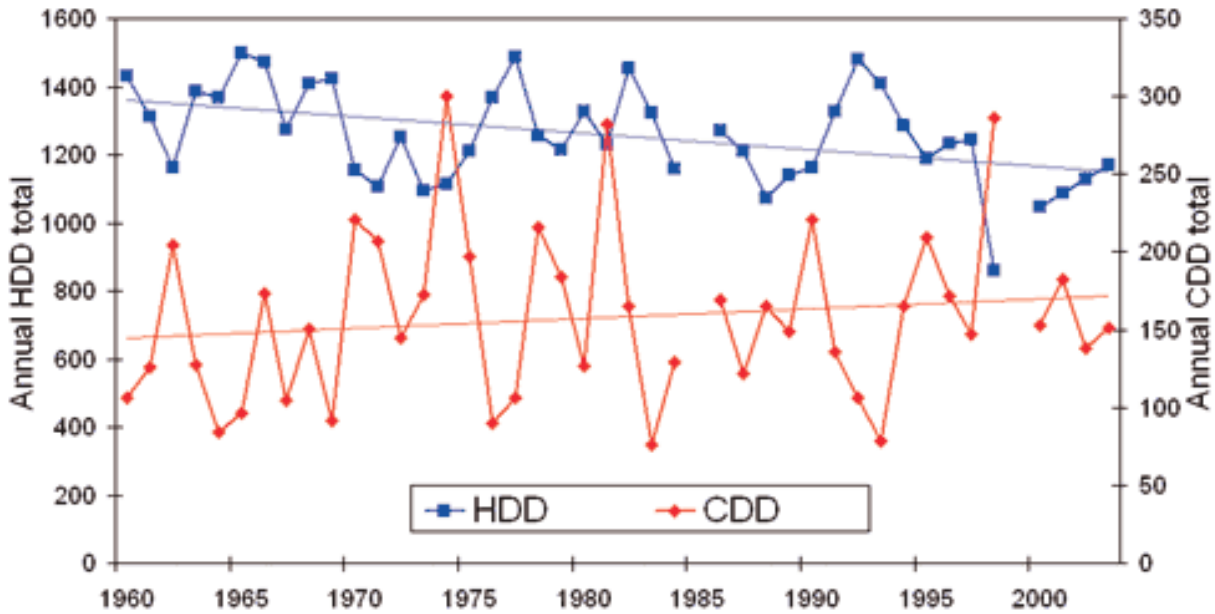

Figure 2.2  
Shift in Cooling and Heating Loads in Auckland 1960-2005

The graph indicates that there has been a general trend over the last 50 years of a reduction in heating load of buildings (HDD) and an increase in cooling load (CDD). Extrapolating the data, it would indicate that energy required for cooling will exceed that for heating in about the year 2040. However, it is likely to be considerably sooner for two reasons;

- 1) Global warming has been accelerating.
- 2) Cooling load is not directly proportional to temperature and the demand for cooling is also related to expectation of comfort and ability to acclimatise. Air-conditioning is addictive.

Source: <http://www.niwa.co.nz/news-and-publications/publications/all/wa/13-4/renewable>

the day. Peak loads of electricity are supplied by gas generators that produce high levels of CO<sub>2</sub> that contribute to climate change.

### The problem of air-conditioning

Research by BRANZ (3) has indicated that the increase in ownership of domestic heat pumps in New Zealand over the next 5 years will require the equivalent of complete electrical capacity of all hydroelectric power stations on the Waikato River (Box 1). However, commercial buildings are likely to have an even greater impact on electricity demand since they remain in operation during peak diurnal temperatures.

To mitigate this, building design should focus on avoiding air-conditioning by adopting passive techniques for cooling buildings. With few specific requirements in the Building Codes and with inadequate recognition of the issue by the Green Building Council, designers are neither compelled nor significantly encouraged to avoid air-conditioning. For example, office developments in Auckland that received 5\* ratings in 2009 ('NZ excellence') are dependent on air-conditioning and have a disproportionately large cooling load.

Building Code standards concerning energy consumption of buildings in New Zealand are some of the lowest

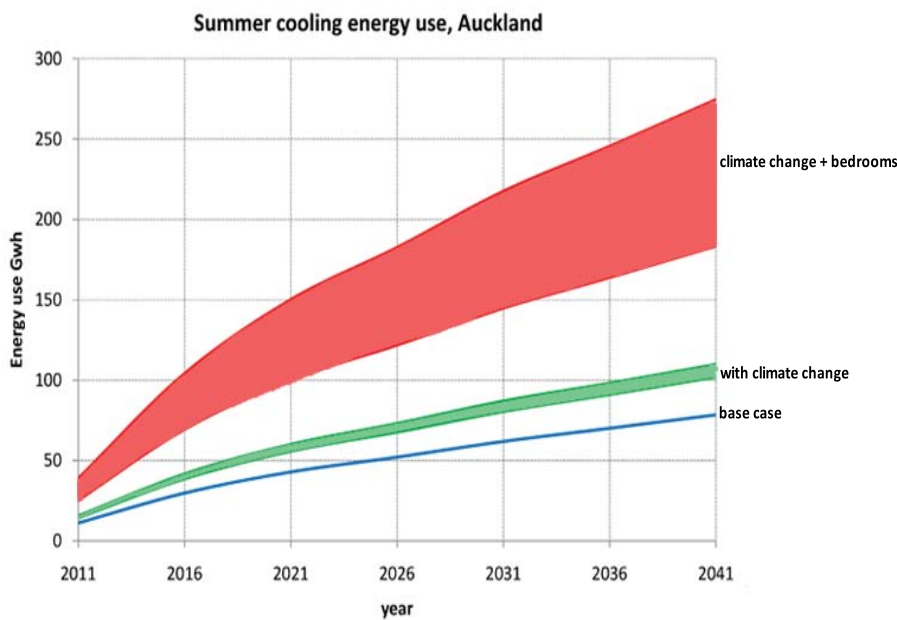
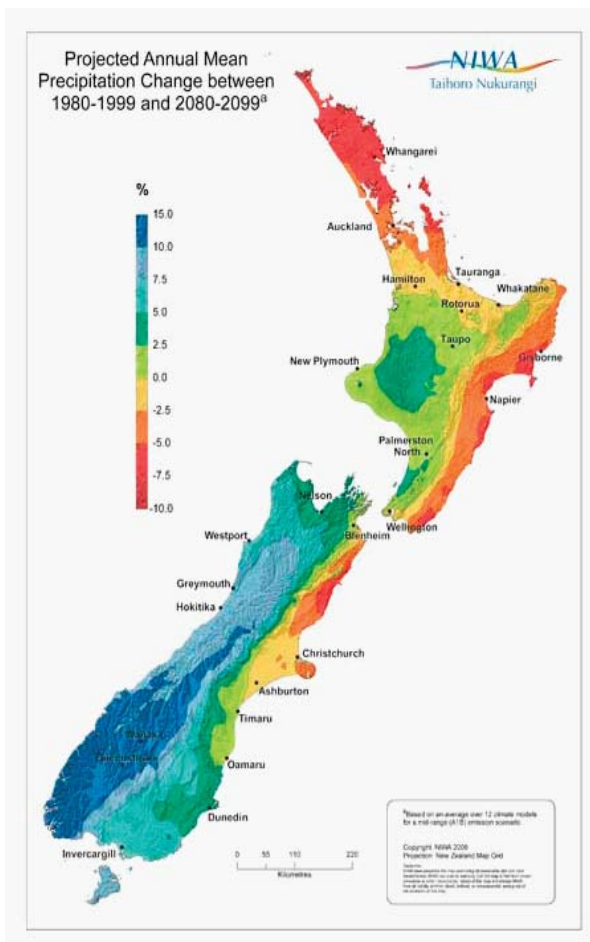

Figure 2.3  
Predicted increase in energy for cooling residential buildings in Auckland. (4) Byrd & Segedin (2010)

The electricity demand for cooling housing in Auckland could increase 5 fold by the year 2040 due to a combination of climate change and the increased use of heat pumps for cooling.



**Figure 2.4**  
**Predicted changes in rainfall in New Zealand**

Reduced rainfall may lead to competition for water between electricity production and irrigation for agriculture.  
Source: <http://www.niwa.co.nz/our-science/climate/information-and-resources/clivar/scenarios>

in the OECD. There are many reasons behind this but the principle ones are the relatively cheap price of electricity and the political will not to increase building costs. As a consequence, the country has lagged behind other OECD countries in its research into low energy buildings. As electricity prices increase and the security of an uninterrupted supply decreases, the energy consumed by buildings will take on a greater significance.

### The problem of water

Increased temperatures will result in the increased use of Heat Pumps and air conditioning for cooling buildings in the summer. This is when rainfall is least and water for irrigation required the most. Climate change will exaggerate this problem due to reduced average rainfall in some areas of New Zealand (Figure 2.4)

In New Zealand, there will be a conflict between supplying water for the production of food or supplying water for the production of electricity a large proportion of which will be for cooling buildings. We can design buildings not to require air-conditioning but we cannot survive without food.



## References

1. NIWA. Climate Change Scenarios for New Zealand. <http://www.niwa.co.nz/our-science/climate/information-and-resources/clivar/scenarios>. Accessed Jan 2012
2. Fitzharris J & Hay J (1989) Glaciers: Can they Weather the Storm of Climate Change? In Proceedings 15th New Zealand Geography Conference, ed R Welch, 284-291, New Zealand Geographical Society.
3. L. French, N. Isaacs, M. Camilleri (2008), Residential Heat Pumps in New Zealand. 29th AIVC conference addressing climate change issues, Kyoto, Japan
4. Byrd, H. & Segedin, E. (2010) New Directions for Research due to Climate Change in New Zealand. paper for the 2010 Australasian Housing Researchers' Conference, Auckland.

# DESIGNING BUILDINGS FOR THE FUTURE CLIMATE

## The environmental control system in buildings

The human species can survive without buildings in most parts of the planet that are currently inhabited. While they may survive, they may not be very comfortable and so our species has attempted, with differing degrees of success, to make life more comfortable by making structures that modify the climate around us and by burning Carbon based materials to provide supplementary heat and light when these are inadequate in the natural environment.

One of the oldest recorded buildings (Figure 3.1) is the mammoth-hunters' tents in southern Russia which archaeologists have dated at about 40,000 years old (Mongait, 1961). Built by trial and error, it shows all the characteristics of climate modification that persist through architecture to modern times. The tent partially insulates the occupants from the external environment while fresh air is brought in through openings and foul air extracted through other openings. Hearths found in the tents were used for fires that could heat and light the interior of the tent.

While architecture now includes the modification of cultural climates (social, political, economic and

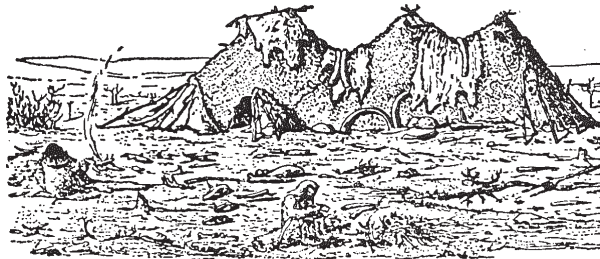
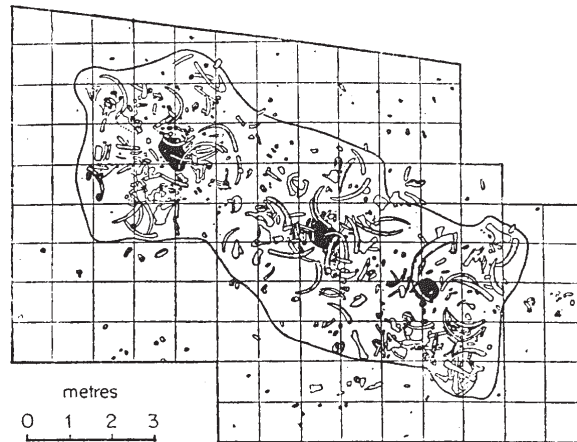

Figure 3.1

The mammoth hunter's tent. The oldest recorded building; 40,000 years old.

Source (1) Mongait, A. (1955)

At one extreme a building could be a cave relying completely on its fabric to modify climate and, on the other extreme, it could be a camp fire without any fabric. The history of environmental control in architecture has been a struggle between these modes of environmental control. One mode consumes energy, the other does not.

aesthetic) the primary function of a building is to provide shelter whether from the rain, snow, wind or sun. A building modifies climate in order to reduce the impact of the external environment both throughout diurnal (night and day) changes and seasonal changes. It does this by providing barriers (walls, roofs, floors) and filters (windows and apertures) that are open to or exclude or store elements of the external climate.

The building envelope is the interface between the internal and external climate of a building and the main characteristics of the envelope that modify climate are the form and fabric of the building.

The fabric includes:

- Thermal insulation: this controls the rate at which energy flows through the fabric either into or out of the building.
- Thermal mass: the extent to which heavy weight materials are used to store heat
- Apertures: permit fresh air, daylight and sunlight into a building and remove stale air.

The form of a building includes:

- The orientation of the building and its apertures
- The building's ability to shade itself
- The building's ability to induce air movement through itself.

These are called passive means of controlling the environment. They require little or no supplementary

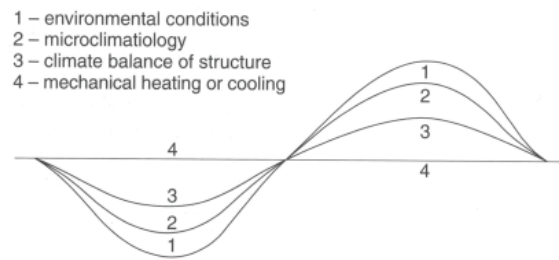

Figure 3.2

“Flattening the curve” Source (2) Olgyay & Olgyay 1963

The external environment can be made more habitable by a process of :

- 1) selecting an appropriate microclimate
- 2) building a structure (passive)
- 3) installing heating or cooling (active)

energy other than ambient energy.

Parts of the building fabric can also be altered and adjusted to control the modifying characteristics of a building. For example, opening a window or operating a shading device. These are called active means and generally require intervention in the form of either occupants or electromechanical devices to operate them. This is illustrated in figure 3.2

However, passive and active means of controlling the environment are limited. They can smooth out the internal temperature over a day, permit light in while daylight is available and even store heat for a period of time. But they cannot generate heat, light or air movement when it is not available in the natural environment.

In order to provide additional environmental control, energy is required to supplement the natural environment. This may take the form of devices that can heat, cool, light or force air movement. These devices need to be activated to take effect, whether by a switch or a match, and are referred to as building services.

The environmental control system of almost all buildings is a combination of passive and active means of the building fabric combined with building services.

A theoretical model of the environmental control system of buildings.

The process of environmental control can be diagrammatically illustrated to show how the processes relate. This concept is central to this text and can be used to analyse the effectiveness of building types, both in providing comfort and in their consumption of fuel.

Figure 3.3a represents the biological response of a human. Environmental disturbances, E, impinge on our natural environment, N, which affect our comfort, C. Our bodies attempt to regulate, R, our biological systems by altering the natural environment and create a simple feed-back loop that can be continually adjusted. An example of this may be a decrease in light that makes

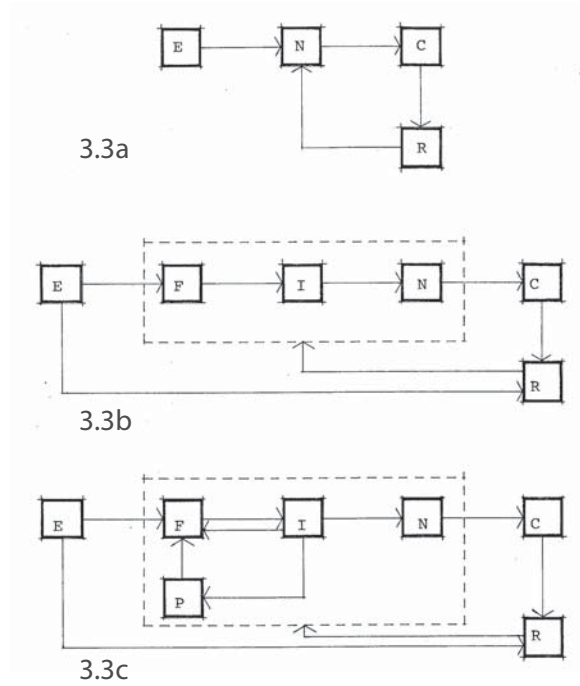

Figures 3.3a to c  
A theoretical model of the environmental control system of buildings

Environmental disturbances, E, impinge on our natural environment, N, which affect our comfort, C. Our bodies attempt to regulate, R, and the building fabric, F, separates further the body from the external environment and creates an internal environment, I. This is then supplemented by building plant, P.

Adapted from; (3) Willey, H.B (1978)

sight more difficult so the eye automatically responds by dilating the pupil.

Figure 3.3b illustrates the introduction of building fabric, F, that separates further the body from the external environment and creates an internal environment, I. The regulating feedback now also controls the fabric.

Figure 3.3c indicates the introduction of building plant, P (building services), which consume energy to regulate the internal environment by altering the building fabric. These can be automated to create their own feedback loop such as a thermostat controlling a heater.

Buildings require resources both for their construction (Fabric) and for their services (Plant) which generally require some form of combustion. Since these resources are finite, it is important that any building uses resources efficiently. Buildings need to find a balance between the resources used in their construction compared with the resources consumed by combustion. However, over the life of a building the energy consumed in its operation is significantly greater than the energy used for construction.

At one extreme a building could be a cave relying completely on its fabric to modify climate and, on

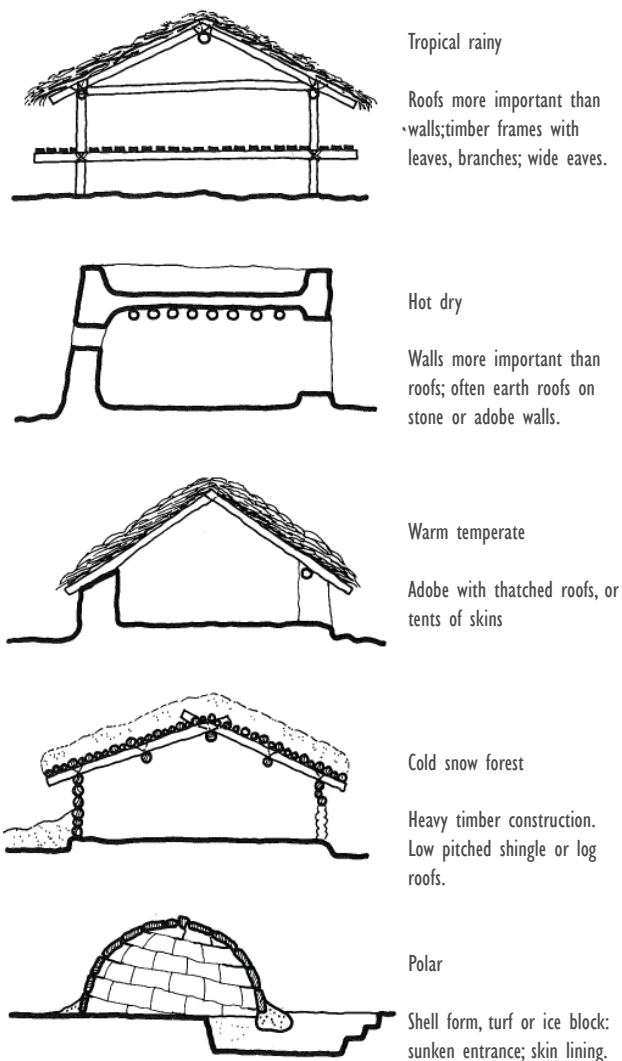

Figure 3.4  
Stereotypical house forms that have evolved in response to climate over the millennia.



## DESIGNING BUILDINGS FOR THE FUTURE CLIMATE

the other extreme, it could be a camp fire without any fabric. The history of environmental control in architecture has been a struggle between these modes of environmental control.

### Designing with Climate

The design of buildings over time has gone through several stages in this process. Early attempts, as we have seen with the mammoth-hunters tents, have been achieved by trial and error. Over the centuries successful attempts have become repeated and culturally adopted so that there becomes a fixed mental image of what a particular building should look like. The evolution of these building types demanded an efficient use of resources and resulted in ingenious designs that were culturally inherited and not architect designed. Figure 3.4 illustrates some stereotypical house forms that have evolved in response to climate over the millennia.

A more ingenious example is the wind-catcher houses in Hyderabad, Pakistan (Figure 3.5) where the kite shape catchers draw cool air through the buildings.

In pre-industrial societies buildings evolved in response to climate, culture and resources. Buildings were tested by the natural environment and successful ones survived.

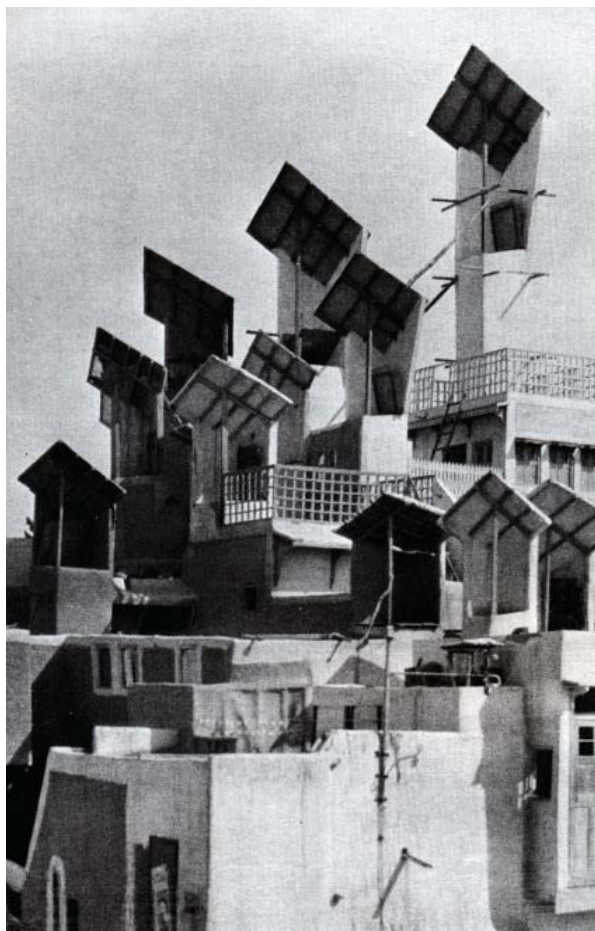

Figure 3.5  
Wind catcher houses cooled passively  
Further examples can be found in: (4)  
Rudofsky, B. (1972)

With industrialisation came new materials, new technologies and new building types. The rapid demand in buildings meant that they could not be tested by nature nor built according to a fixed mental image.

### Designing for a Changing Climate

With industrialisation came energy and architects as well. Buildings that were failures in appropriate environmental control could overcome their shortcomings by pumping in energy to cool, heat or light themselves.

Mankind now lives in an era when we are aware that our energy resources are finite and production is declining and this presents building designers with two main issues:

- 1) Existing buildings that cannot operate without a significant amount of energy need to be adapted to suit the future climate.
- 2) New buildings should be designed not for the present climate but for a future climate that is hotter and has less energy.

In New Zealand the challenge will be to design new or adapt existing buildings to reduce their energy consumption and, in particular, their demand for cooling. This requires an understanding of techniques of using ambient energy to reduce the demand on

imported energy.

These techniques include:

- 1) Maximising the use of natural light so that artificial lighting can be minimized. This not only saves electricity for lighting but also reduces a cooling load due to the heat given off by the lights.
- 2) Installing lighting systems that minimize energy demand and can respond to the availability of daylight.
- 3) Shading a building so that it can utilise solar energy when it has a heat demand but exclude it when there is a cooling demand.
- 4) Naturally ventilating a building in order to avoid air-conditioning.
- 5) Exploiting the thermal mass of a building to either retain heat or maintain a cool temperature.
- 6) Utilising the landscape around buildings to enhance the natural cooling.
- 7) Integrating renewable energy technologies to provide an alternative source of energy.

The following chapters will provide guidance in the techniques to achieve selective environmental control often referred to as “low energy” or “low carbon” buildings.

## References

1. Mongait, A. (1955) *Archaeology in the USSR*, Penguin Books.
2. Olgyay, V. & Olgyay, A. (1963) *Design with climate : bioclimatic approach to architectural regionalism*. Princeton University Press.
3. Willey, H.B (1978) *A Theoretical Framework of Environmental Control*. PhD Thesis, Cambridge University.
4. Rudofsky, B . (1972) *Architecture without architects: a short introduction to non-pedigreed architecture*. London, Academy Editions

# PASSIVE SOLAR ENERGY in the VISIBLE SPECTRUM

## Daylighting as an Almost Free Energy Source

Daylight is solar energy in the visible spectrum and is an almost free source of energy for lighting buildings. When daylight is inadequate, buildings supplement this light with 'artificial lighting' that consumes electricity. In order to reduce energy consumption, buildings should be designed to make the best use of daylight.

Not only does daylight reduce energy consumption of artificial lighting but it also reduces the cooling load of a building in a hot climate. Artificial lighting produces heat: the amount of heat depending on the efficiency of the lamps and the level of light they provide. A room that is artificially lit by fluorescent lamps will also be heated by the lamps at a rate of about 12 Watts for every square meter of floor for every 100 lux. This is discussed further in the next chapter.

Diffuse daylight also heats a building but the amount of light (lumens) that it provides compared with the energy (Watts), in the form of heat, that it produces is less than artificial light. The amount of diffuse daylight on a horizontal surface varies in different climates and latitudes but has an efficiency ("efficacy") of about

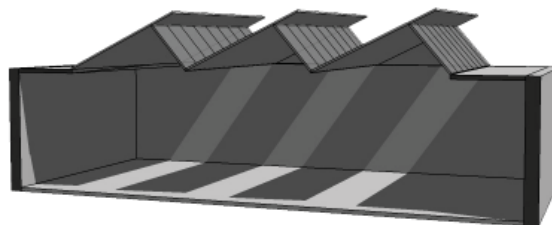

Figure 4.1  
Windows in a roof should be a maximum of 5-10% of the floor area and be protected from direct sunlight.

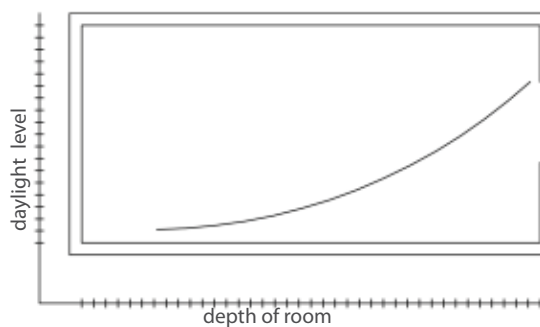

Figure 4.2  
Daylight decays exponentially with room depth

120-130 lm/W (Ullah 1996).

An energy-efficient fluorescent lamp has an efficacy of about 80 lm/W. Therefore, daylighting will produce about half the heat of artificial lighting for the same light levels.

### The distribution of daylight in a room

The problem is that daylighting usually comes into a room through windows at the side of a building and the light is not evenly distributed. The light level near a window may be too much while, at the back of a room, it may be too little. The amount of light in a room depends on the size of the opening, the amount of light reflected within the room and the distance of the back of the room from the window ("room depth").

Apertures in the roof of a building allow daylight to be more evenly distributed in rooms below. However, most solar radiation falls on roofs so the aperture should be well protected from direct sunlight or even reflected sunlight from an immediately adjacent roof. Where daylight enters from a roof and can be evenly distributed, the area of aperture need only be approximately 5% of the floor area depending on the level of light required and extent of shading (Figure 4.1).

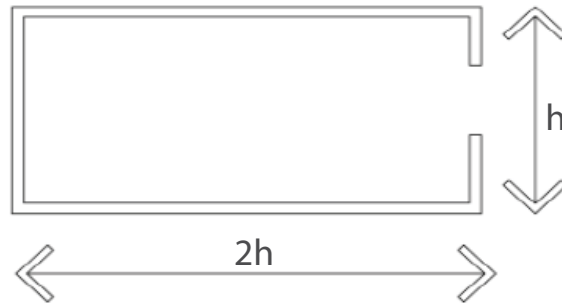

Figure 4.3  
Maximum depth of a room for beneficial daylight with windows on one side only.

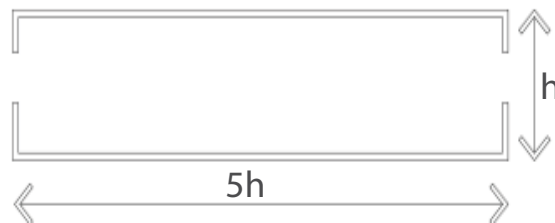

Figure 4.4  
Maximum depth of a room with windows on opposite sides

## PASSIVE SOLAR ENERGY in the VISIBLE SPECTRUM

The amount of daylight entering a room from side windows decays exponentially with the room depth (Figure 4.2). It is generally accepted that the depth to which daylight can be beneficial within a room is limited to twice the height of the window in the room (Figure 4.3). This is an approximation and depends on many factors including the type of shading devices at the window, type of glass and the level of artificial lighting (“service illuminance”) within the room. The area of a room that is deeper than twice its height is generally considered to require ‘permanent artificial lighting’. Rooms that have windows on opposite sides have a good distribution of daylight and the overall width of the room can be increased to about 5 times the height of the window to give reasonable autonomy of daylight (Figure 4.4).

### Uniformity of light as a means to save energy

In order to save energy, the designer needs to try and distribute daylight as far into the room as possible. This can be achieved by increasing the size of the window. However, after a certain size this can become a disadvantage for several reasons. It can cause glare from the window, it can introduce direct solar radiation and, although the room may have more light, it will not be perceived to have more light since the ratio of light near the window compared with the back of the

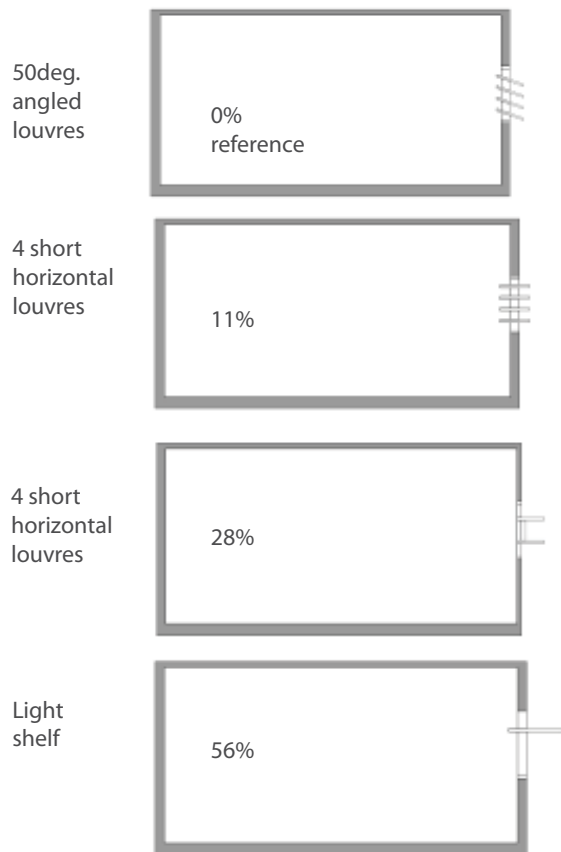

Figure 4.5

% improvement in daylight at the back of a room compared with reference room with different shading devices all giving the same solar protection (Oteiza & Soler, 1995)

$d_2$  should not be greater than  $h_2$

$d_1$  should not be greater than  $h_1$

minimum ceiling height  
3m

lightshelf as reflective as possible

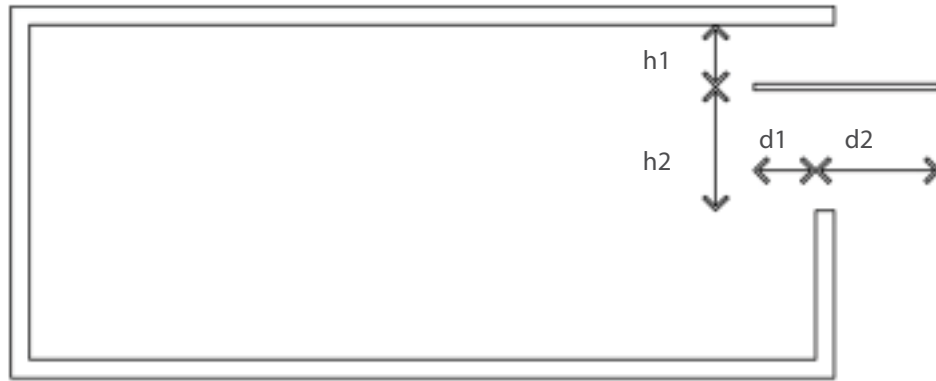

**Figure 4.6**

Optimum dimensions for a lightshelf (Littlefair 1995)

room (“uniformity”) will remain the same (Byrd 1979).

The human eye does not measure ‘absolute’ levels of light it can only perceive ‘relative’ levels of light. It is possible to read a newspaper under moonlight that has a light level of about 0.5 Lux. It is also possible to read a newspaper in the sunlight that may be 5000 lux. A room will be perceived as ‘dark’ by the eye if there is a strong contrast (lack of uniformity) of light within the room. Under these circumstances people tend to turn lights on even if there is adequate daylight. A uniform distribution of daylight within a room reduces glare and can help to reduce energy consumption due to artificial lighting.

Techniques for the uniform distribution of daylight.

In hot climates shading windows to obstruct direct solar radiation is essential. Different types of shading can also be used to redirect daylight from the front of a room to the back. Different types of shading device have different efficiencies in redistributing daylight. Shading devices increase uniformity of daylight both by reducing the light level at the front of a room and by slightly increasing light levels at the rear.

Figure 4.5 illustrates the effectiveness of 4 different types of shading device compared to a room where the window had no shading (reference model). To make the comparison fair, the shading devices are all designed to equally protect the windows from direct solar radiation (Oteiza & Soler 1995).

## PASSIVE SOLAR ENERGY in the VISIBLE SPECTRUM

All of the rooms with the shading devices have more uniform lighting than the reference model and more light at the back of the room with the exception of room A. This has lower illuminance since the shading device does not redirect light inside the room. Figure 5 indicates that the 'light-shelf' is the most efficient way of redistributing daylight within a room.

To optimise the design of the light shelf, the geometry needs to be carefully considered so that it does not obstruct daylight (Littlefair 1995).

Light shelves have to extend outside a building and into the building. They should be of high reflectance and the room height should not be less than 3 metres. The optimum geometry is illustrated in figure 5.6. In hot climates, it is better to separate the internal and external shelves so that heat is not conducted from outside to inside. They should also be of a lightweight material so that they do not radiate heat into the room at night.

### Optimising the size of a window.

For naturally ventilated rooms, in warm climates, the size of the aperture will be dictated by ventilation needs. For air-conditioned rooms there is a balance to be made between the useful energy entering a room for daylighting and the unwanted thermal energy that results in an increased demand on cooling. A useful

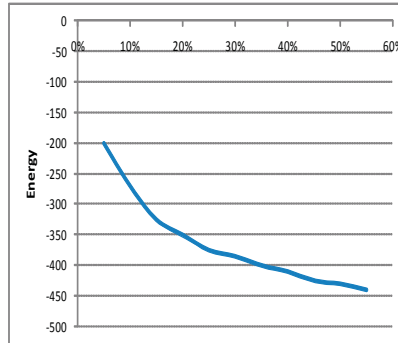

Figure 4.7a

Energy savings from artificial lighting diminish with larger % of glazing

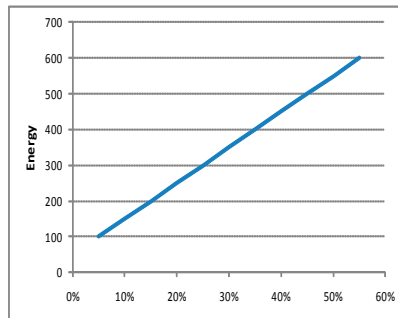

Figure 4.7b

Costs of airconditioning increase linearly with % glazing

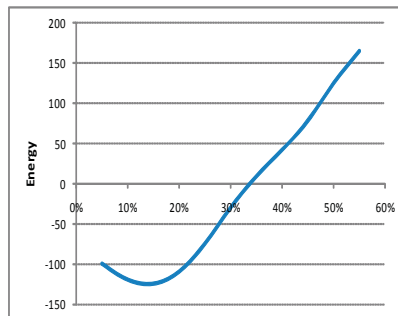

Figure 4.7c

Overall optimum %glazing

(adapted from Lam et al 1998)



way of comparing the 'visible' and 'thermal' energy entering a window is to relate it to the proportion of a window within a wall ("glazing") (Figure 4.7) (Lam et al 1998).

Figure 4.7a illustrates the energy saving by daylight and (Figure 4.7b) the energy consumed by electricity for cooling in relation to the 'glazing'. These two graphs can be combined to show the overall effect. Figure 4.7c illustrates that there is an optimum 'glazing' which lies somewhere between about 15% and 35%. Areas of glazing below or above these amounts rapidly become inefficient for air-conditioned buildings.

The curve indicating the optimum will vary depending on the light transmission of the glass, the shading factor, orientation of the window and internal service illuminance. However, many of these factors cancel each other out the proportion of window area within

a wall will also be determined by other factors that may have importance. For example, the view from a window, noise levels outside and the character of the building façade.

#### Types of glass and their effect on energy use.

Glass has 3 important properties that effect its performance in balancing the thermal and visible energy entering a window.

- a) the amount of light that can pass through ("transmittance")
- b) the amount of heat that can pass through by conduction (" U value")
- c) the amount of heat that can pass through by radiation. ("shading coefficient").

Table I. shows the properties of different types of glass.

**Table 1**

Type of glass	Shading Coefficient	Light Transmission	Uvalue
Clear	0.9	0.85	6.2
Tinted	0.7	0.5	6.2
Reflective	0.4	0.3	5.6
High Perform.	0.51	0.55	1.8

**% glazing vs. satisfaction with adequate view out of window**

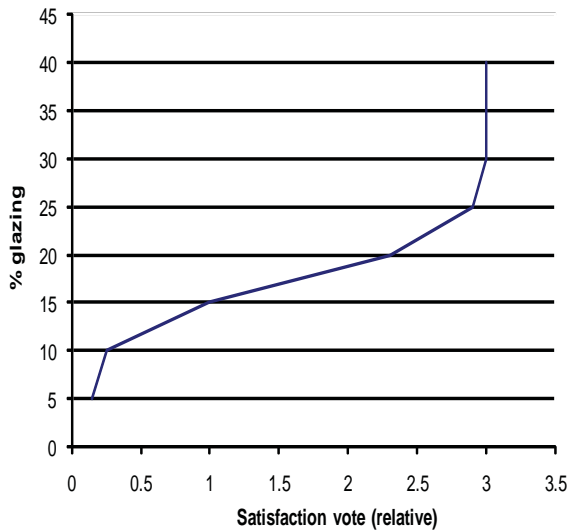

**Figure 4.8**

**Satisfactory view vs window area**

The research found that satisfaction of views out of a room dramatically reduced when the proportion of glazing fell below 10%. Over 10% and the satisfaction grew gradually. However, there was virtually no increased satisfaction with glazing over 30%.

Adapted from Keighley, E. C. (1973) Visual Requirements and Reduced Fenestration in Offices. Building Science Vol 8. pp321-331

A common misconception combined with clever marketing, has resulted in the extensive use of tinted glass as a means of reducing temperatures and air-conditioning load. However, for the same amount of daylight within a given room, clear glass is more energy efficient than tinted glass and reflective glass.

Isq meter of clear glass allows 90% of radiant heat through. To achieve the same amount of daylight, a window of tinted glass would need to be 1.7 times larger (0.85/0.5). 1.7 sqm admits (0.4 x 1.7 = 1.19) (119%) of radiant heat. Therefore, for the same amount of daylight, tinted glass admits 29% more radiant heat. Reflective glass admits 10% more heat

for the same amount of light.

From the point of view of energy efficiency, tinted and reflective glass are not efficient. It is better to have smaller areas of clear glass. 'High performance' glass is more energy efficient but this must be balanced against its additional cost.

However, tinted and reflective glass reduce glare if there is inadequate shading. The shading methods described above, not only reduce glare from direct sunlight but also are more effective at producing more uniform lighting distribution.

### Optimising energy savings from daylight.

In the section above on 'Uniformity of light' it was assumed that the occupants of the building would switch off lights if the daylight was adequate. This cannot be relied upon and, therefore, devices have been manufactured to do this for them.

This is discussed further in the chapter on Artificial Lighting. However, research (Ullah et al 1996) has shown that within 6 metres of the perimeter of an office, automatic dimming can save about 84% of the energy required to artificially light the space. On/off switching can save about 34% energy. However, this research assumed a light level of 500 lux internally which is now considered to be a high level. With lower artificial light levels, the savings will also be lower.

### Views from windows

The size of a window is derived not only from the requirement to daylight a space but also from the desire to have a view out. For buildings that are workplaces the requirement for a view is a subjective criterion and designers frequently oversize windows for this purpose.

Research in this field has identified two separate needs for occupants:

- 1) the psychological need to have a visual connection with the outside and
- 2) to reduce eyestrain for building occupants by allowing long distance views.

In the case of psychological need, extensive research (Keighley 1973) showed that user satisfaction was related to the area of glazing in the external elevation. When the window area was less than 30% of the wall area, satisfaction began to drop off and then plummeted when glazing was less than 10%. Interestingly, there is no increased satisfaction with the glazing area above 30%. This is illustrated in Figure 4.8.

In the case of eyestrain, the need is to be within a reasonable distance of a window (generally 8m maximum) that has an external view. This has no implications on the amount of glazing in an elevation.

### References

- Ullah M (1996) International Daylight Measurement Programme-Singapore. Lighting Research and Technology, Vol. 28 (2), pp 75-81
- .
- Byrd, H & Hildon, A (1979) Daylight: Appraisal at the Early Design Stages. Lighting Research & Technology Vol. 11 No 2 pp 99-101

P Oteza and A Soler (1995) A Comparison of the Daylight Performance of Different Shading devices Giving the Same Solar Protection. *Architectural Science Review*. Vol. 38, pp 171-176

Littlefair P J (1995) Light Shelves: Computer Assessment of Daylight Performance. *Lighting Research and Technology*. Vol 27 (2) pp 79-91

Lam JC et al (1998) An analysis of Daylight Energy Performance Using Computer Simulation Techniques. *Architectural Science Review* Vol. 41 pp 145-156

Keighley, E. C. (1973) Visual Requirements and Reduced Fenestration in Offices. *Building Science* Vol 8. pp321-331

# LOW ENERGY ARTIFICIAL LIGHTING

## Reducing Energy Consumption by Artificial Lighting

Artificial lighting can be defined as light produced by sources other than daylight. The light is produced by 'burning' fuel, for example, Kerosene or gas. However, the most common form of artificial light is produced by electricity heating an element or being discharged through a gas. It is often thought that electricity is 'clean' energy because the user does not see the fuel being burnt. However, the production of electricity by the burning of fossil fuels is very inefficient and produces large quantities of CO<sub>2</sub>, SO<sub>2</sub> and NO<sub>x</sub>. For this reason the use of artificial lighting should be minimised in buildings and, where it is used, lighting systems should be designed to reduce energy consumption.

The inefficient design of artificial lighting systems in hot climates has a double penalty. Firstly, the energy consumed by the lighting can be excessive and, secondly, because the lighting produces heat it will increase the energy consumption of cooling systems. This chapter analyses the methods for reducing energy consumption by artificial lighting.

## Strategies for Low energy lighting systems.

The art of energy efficient artificial lighting is to get the correct amount of light in the correct place at the correct time. There are 4 ways of reducing energy consumption by artificial lighting:

- 1) Maximise the use of daylight. This is described in the previous chapter and involves: designing rooms that are not deep in plan, increasing internal reflectance, maximising the uniformity of light within a room and maximising window areas without admitting excessive solar heat gains.
- 2) Using the appropriate lighting system. The purpose of this is to ensure that light is provided only where it is required.
- 3) Using the correct type of lamps. Different lamps have different efficiencies, different colour rendering and different life-spans.
- 4) Designing a lighting system that is responsive to daylight. This requires switching arrangements that can turn off or dim artificial lighting when daylight is available.

## Lighting requirements.

The simplest way of saving energy is to ensure that light levels are not exceeded. Table 1 indicates the light levels that are commonly recommended for different spaces. The human eye does not work like a light level meter. It adapts and is able to respond to large variations in light levels from moonlight (0.5 lux) to sunlight (50,000 lux). The light levels indicated in the table, provide visual comfort for the majority of people. However, as fuel prices increase, these levels will become increasingly under review in order to save energy. For example, the level of 500 lux was commonly specified for office spaces. This has now been reduced to 300-400 lux. The recommended light level is on the 'working plane'. In an office this would be at desktop height. However, perception of lighting artificial lighting within a room is more associated with levels of light on walls and ceilings. Light fittings recessed into ceilings were commonly specified to reduce glare on Visual Display Units (VDUs). These types of fittings provided the correct light level on the working plane, but made rooms appear to be dark giving little incentive to turn off lights. Estimating the number of light fittings required to light an area. The amount of electrical energy (Watts) required for a light fitting to produce a certain amount of light (lux) over a given area (square meters) can be calculated accurately using the "Lumen Method" [1]. This is a

**Table 1**

### Recommended Light Levels

Room Function	Light Level (lux)
Circulation areas	100
Enclosed car parks	30
WCs, locker rooms	150
Restaurants	100-150
Workshops	300-500
Kitchens	500
Offices	300
Drawing office	500
Libraries shelves	150
reading rooms	300
Lecture theatres	300
Laboratories	750

## LOW ENERGY ARTIFICIAL LIGHTING

complicated calculation and is now most commonly used with engineering software packages. A simpler way of estimating the energy required is the use of a simple formula:

For conventional ceiling mounted, energy efficient fluorescent light fittings the amount of electrical energy required to light one square metre of a room to a level of 100 lux is approximately 3Watts: 3W/m<sup>2</sup>/100 lux.

An example calculation is shown in box 1. This is a simple method of calculating the amount of light fittings required to adequately light a space. It assumes

normal ceiling heights and high levels of internal reflectance (white walls and ceiling). This calculation not only indicates the number of light fittings required but also calculates the heat gain due to artificial lighting. In the example in box 1, the air-conditioning load in the room will be increased by 324 Watts due to artificial lighting.

### Types of Lamp and Lamp Efficiencies.

The efficiency (efficacy) of a lamp is measured by the light it emits (lumens) per watt of electricity it consumes. Table 2 indicates the approximate efficacies of some common types of lamp. The most common

Table 2

#### Efficacy & colour rendering of different lamps

Type of lamp	Efficacy lm/w	Colour rendering
Tungsten	10-20	1 (good)
Tungsten Halogen	30	1
LED	40-80	1
Fluorescent (T5)	90	1
High Pressure Sodium (SOX)	135	3 (poor)
Low Pressure Sodium (SON)	200	yellow light

energy efficient type of lamp used inside buildings is the fluorescent lamp which has a good balance of colour rendering with energy efficiency.

In general, Tungsten and Tungsten Halogen lamps are very inefficient and are used for display lighting. Light Emitting Diodes (LEDs) are improving in efficiency and have a lifespan that can be 2 - 4 times greater than fluorescent lamps. However, at present, they are uneconomical for normal lighting of the interior of buildings. High efficiency lamps such as High (SOX) and Low (SON) Pressure Sodium, produce light with poor colour rendering and are not normally used for interior lighting.

### Energy Efficient Layout of Lighting Systems in Working Environments

It is common to try and artificial illuminate a space as evenly as possible. This is desirable where the working plane needs to be flexible. However, this results in the floor being illuminated to the same level as the desk or work area. Lighting the floor to high levels is energy inefficient. Therefore, alternative lighting systems should be considered which illuminate the working area more efficiently.

Figure 5.1 illustrates 4 options for illuminating the working area and the efficiencies of the different

#### Box 1

Calculate the electrical energy required to achieve 300 lux, using energy efficient fluorescent lamps, in an office with a floor area of 36 sqm .

- 3 watts are required to illuminate 1 sqm to a level of 100 lux
- 9watts are required to illuminate 1 sqm to 300 lux
- 324 watts are required to illuminate 36 sqm to 300 lux.

If 36W lamps are used, then 9 lamps are required.

This assumes normal ceiling heights and high levels of internal reflectance (white walls and ceiling)



## LOW ENERGY ARTIFICIAL LIGHTING

Figure 5.1  
Options for Illuminating the Working Plane to 400  
lux

1.  
Uplighters  
10 W/m<sup>2</sup>  
Uneconomical but flexible

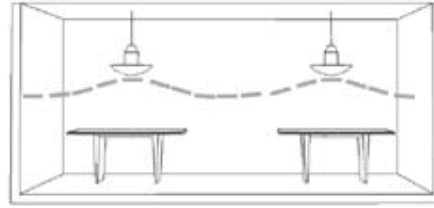

2.  
Background & Task,  
9 W/m<sup>2</sup>  
Most economical and flexible

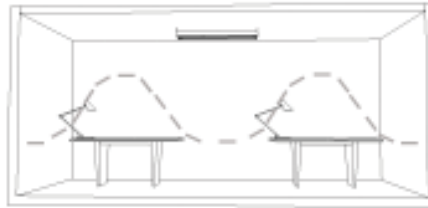

3.  
Localized  
12 W/m<sup>2</sup>  
Less flexible, average energy efficiency

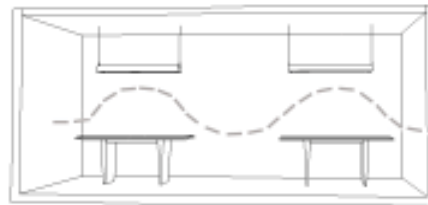

4.  
Conventional  
15 W/m<sup>2</sup>  
Flexible & economical but higher energy cost

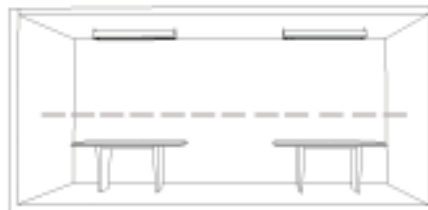

systems.

1) The 'conventional' ceiling mounted light fittings that produce an even light distribution over both the work area and the floor. This is a flexible system but is the least energy efficient. However, it can be made more efficient with automatic dimming provided the lamps have the correct ballast.

2) 'Localised' lighting where the light fittings are lowered over the work area giving lower light levels on the floor. This is only feasible where the work areas are fixed.

3) 'Background and task' lighting is probably the most energy efficient since the background light level can be low and the working area can be well lit. This system would be most appropriate for LED lamps should they become more efficient and cost-effective.

4) Uplighters provide an energy efficient solution only because the lamps that can be used are more energy efficient than fluorescent. It provides a flexible working area and the fittings reduce the risk of glare. However, the lamps may not have such good colour rendering as fluorescent lamps.

## Switching Arrangements

Artificially illuminating the interior of buildings is not only achieved by the use of efficient lamps and lighting systems but also by reducing the amount of time that lights are in operation. People cannot be relied upon to turn lights out and so other switching arrangements are available.

The effectiveness of switching arrangements depends on the whether spaces are used for long or short periods of time, how large the space is and whether the switching will disrupt other users within the space. Table 3 compares the relative cost-effectiveness of the different types of switching arrangements.

The main types of switching are:

1) Central timing: the lights automatically switch off at pre-set times (e.g. lunchtimes and evenings). This means lights will not be left on all day or remain on in the evenings if there is no occupation of the space.

2) Occupancy detection: lights are automatically switched off unless people are detected by either sound or body heat.

3) Automatic dimming: an external photocell will control the automatic dimming of lights as daylight increases.

**Table 3**

**Cost effectiveness of switching arrangements**

Room size and use	Central Timing	Occupancy Detection	Automatic Dimming
Small rooms Continuous use	2		3
Small rooms Intermittent use	3	2	
Large rooms Continuous use	1	2	1
Large rooms Intermittent use	1	1	

Cost-effective scale: 1= good, 2= medium, 3= worth considering in specific situations.

**References**

I. CIBSE (2004), Code for Lighting. Chartered Institute of Building Services Engineers ISBN: 0750656379

International Energy Agency. (2006) Light's labour's lost: Policies for Energy-Efficient Lighting. France : OECD Publishing, 2006.

# SHADING BUILDINGS

## Passive measures to avoid overheating

Solar energy can be of benefit to a building particularly in the winter or for pre-heating on cold mornings. However, it can also have negative impacts as excessive solar heat gains can result in buildings overheating. Solar shading, combined with other passive measures can limit the overheating of buildings and reduce or eliminate the need for air conditioning.

There has been a general trend in increased temperatures in New Zealand (Figure 2.2 ) and Global Warming is predicted to continue this trend. In areas of the North Island building energy use is shifting from a net heating load to a net cooling load which will not only increase the overall demand on electricity but will also contribute to peak demands of electricity in the summer.

This chapter focuses on practical techniques that can be implemented by designers to reduce overheating by different forms of solar shading. There are three basic methods of shading:

1. Orientation of a building (in particular the

positioning of glazing).

2. Different types of blinds including overhangs, landscaping and meshes
3. Solar control glazing and films.

All of these methods require an understanding of solar geometry.

## Shading to avoid air-conditioning

As the climate gradually warms and the cooling requirement for buildings increases, avoiding heat gains within a building also increases in importance. These heat gains are from two principle sources:

1. Internal heat gains such as lights, computers, people and other equipment. These may typically range from about 15 W/m<sup>2</sup> to 30 W/m<sup>2</sup>.

2. Solar heat gains which come from both diffuse daylight and from direct sunlight. The energy from direct sunlight into a building varies with orientation and season but can range from 300 W/m<sup>2</sup> to over 1000 W/m<sup>2</sup>.

Avoiding unwanted solar heat gains is essential if a designer is to reduce energy consumption by air-conditioning or even avoid the need for air-conditioning. This is achieved by shading a building and, in particular, shading the glazing on a building envelope.

### Solar geometry

To model how to shade or allow solar access into a building at an appropriate time an understanding of the movement of the sun is necessary.

In the southern hemisphere the maximum solar altitudes (12 noon) are:

summer:  $90^\circ - (\text{Latitude angle} - 23.5^\circ)$

equinox:  $90^\circ - \text{Latitude angle}$

winter:  $90^\circ - (\text{Latitude angle} + 23.5^\circ)$ .

### Figure 6.1

Universal sundial for the southern hemisphere calibrated for New Zealand cities.

Instructions:

Copy the image and cut out the outline.

Glue onto card folding the paper over the edges for neatness.

Cut out the slot for the angle segments.

Make a gnomon from a match stick to the length indicated and glue down in the centre of the dial.

The gnomon should be at right angles to the dial.

Bend the base of the card and locate the segmented angles into the slots. Bend the base until the desired angle (city) is visible above the dial plate.

Note that sundials of this scale are not accurate enough to tell the time and do not account for daylight savings nor do they account for the eccentricity of earth's orbit (analemma). However, they are of reasonable accuracy for studying shadows cast by a building or solar projection into a building.

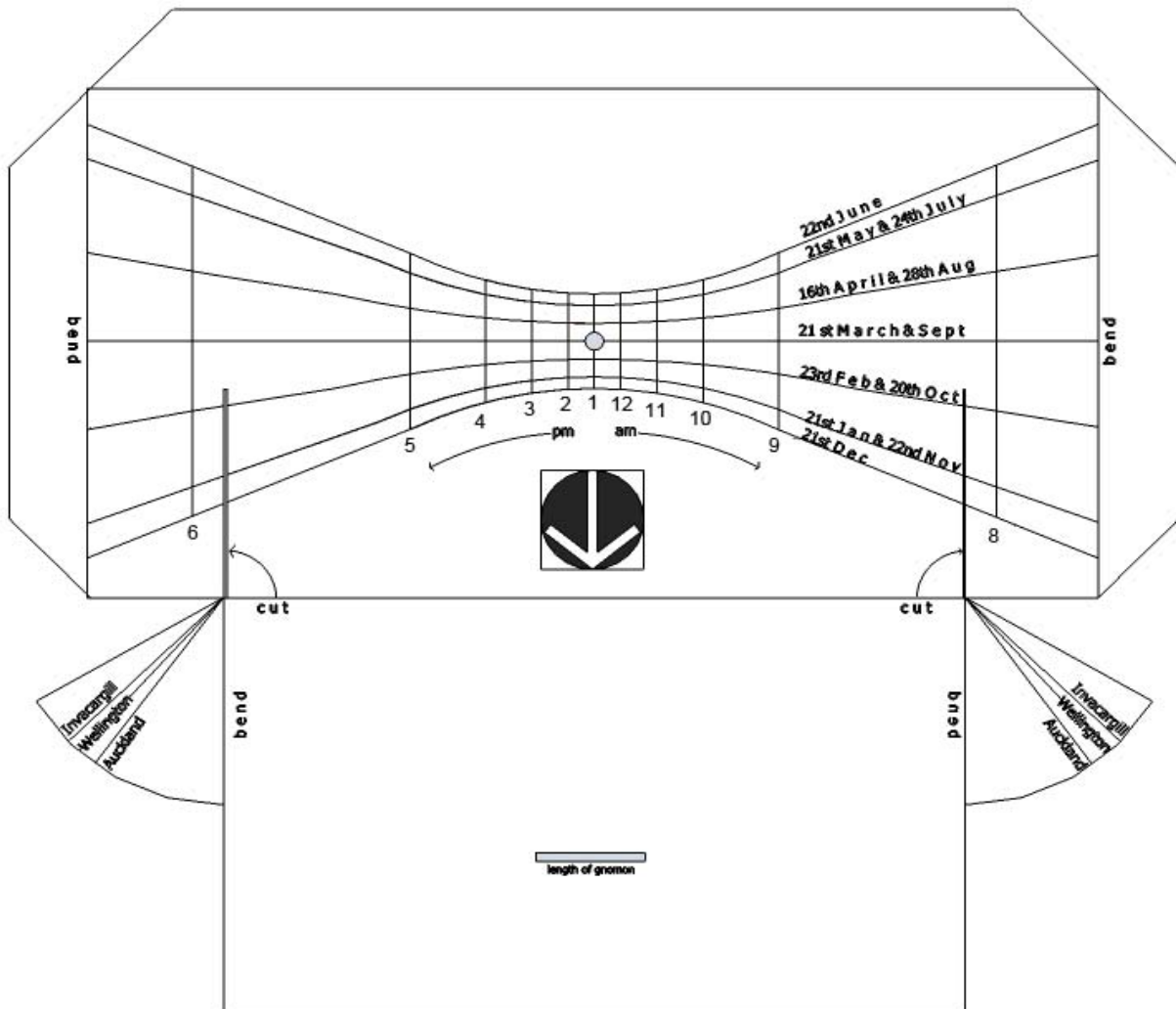

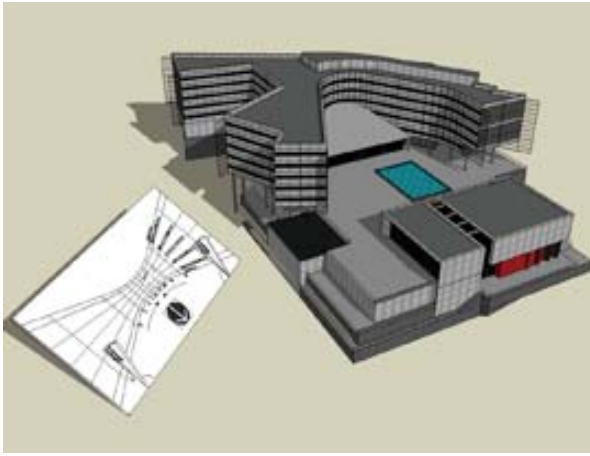

Figure 6.2

Using a Sundial with a Physical Model

Point the sundial towards the north together with the model.

Any point source of light, including the sun, can be used to simulate the sun.

Place the sundial next to a physical model of the building and tilt/turn the model together with the sundial in order to analyse the shadows or solar penetration at any time of the day or year.

Typical maximum solar angles for various places in New Zealand are indicated in Box 1.

Box 1

	Latitude angle	Maximum solar altitude		
		Summer	Equinox	Winter
Auckland	36.5	77	53.5	30
Wellington	41.2	72.3	48.8	25.3
Invercargill	46.2	67.3	43.8	20.3

Tracking the sun throughout the day and year.

There are several methods of predicting the sun's angle of azimuth and altitude.

- a) Most CAD software packages
- b) Sunpath diagrams ([http://www.victoria.ac.nz/cbpr/documents/pdfs/akl\\_sunpath.pdf](http://www.victoria.ac.nz/cbpr/documents/pdfs/akl_sunpath.pdf))
- c) physical model and heliodon or sundial.

Figure 6.1 is a universal sundial for the southern hemisphere. The diagram can be photocopied and assembled as indicated in Figure 6.2.

### Blinds to intercept solar radiation.

When solar radiation impinges on a glass surface a proportion of the energy will be reflected back, some will be transmitted through the glass and some absorbed by the glass (and subsequently reradiated both internally and externally). The most effective way of controlling overheating is to intercept the sunlight before it reaches the glazing.

External blinds are generally in the form of overhangs, brise soleil, vertical and horizontal louvers and awnings. Some common examples of this are indicated in Figure 6.3.

Although external blinds can reduce glare they may also reduce daylight. Installing brise soleil rather than solid overhangs or blinds can reduce this effect.

Blinds installed between two panes of glazing are less effective than external blinds (figure 10.6 ). However, they have the potential to be kept clean and operated from the inside more easily.

Internal blinds are the least effective at reducing overheating. Much of the energy absorbed by the blinds will be reradiated internally. Solar reflective blinds or fabrics are a marginal improvement.

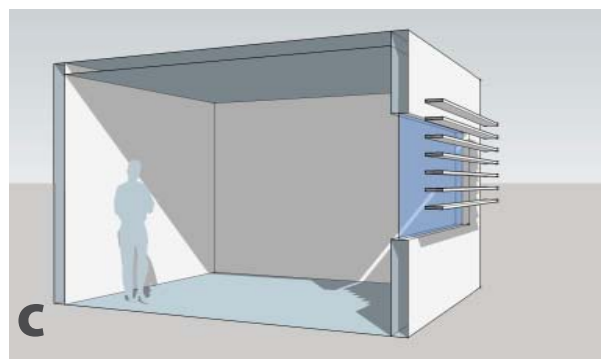
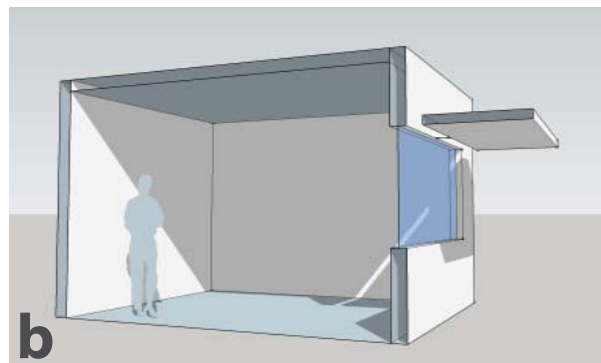
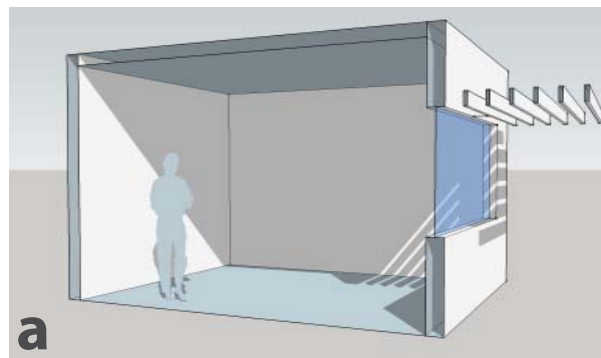
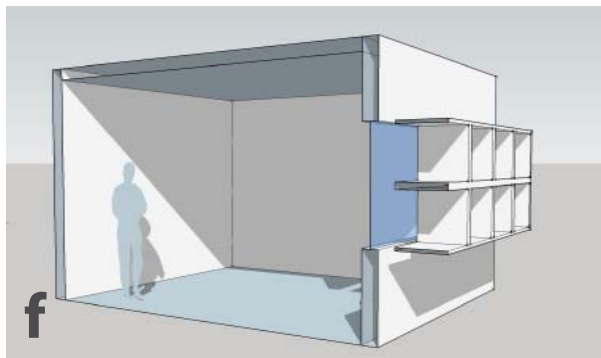
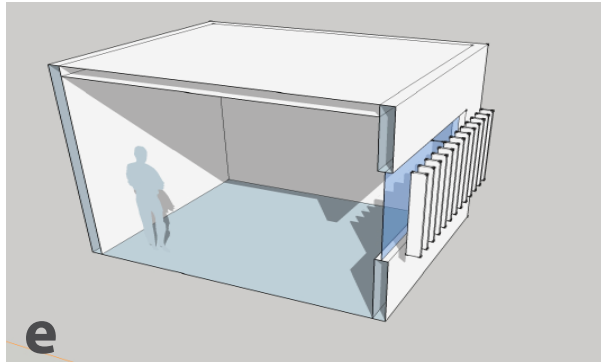
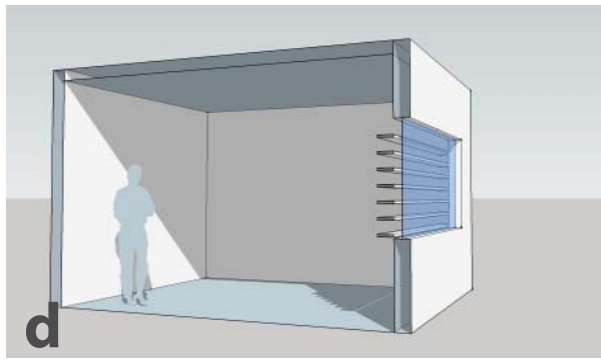

Figure 6.3  
Typical examples of shading devices





Typical fixed blinds for shading windows.

a) Brise Soleil; optimum shading with some loss of daylight.

b) Solid shelf or overhang. Good solar shading but reduced daylighting (unless used as a light-shelf as Figure 4.6).

c) Horizontal external blinds; can block views but can be motorised to tilt the blades.

d) Internal blinds (vertical or horizontal) of little benefit for solar heat gains but can reduce glare. Easily maintained and adjustable.

e) External vertical louvres; of little benefit for high angles of sun. More appropriate for westerly and easterly orientations when the sun is low. Can be motorized for optimum shading.

f) Egg-crate louvres; effective for shading at both high and low sun angles. Reduce daylight and views. Reduce air movement for natural ventilated buildings and can pre-heat air entering through windows.

### General principles of blind systems.

- Internal blinds can be useful to reduce glare but much of the solar energy absorbed by them is re-radiated into the room.
- External louvers should minimise the amount of daylight they obstruct.
- External louvers or canopies should be lightweight. Heavyweight canopies store heat during the day and re-radiate it at night. This reduces the ability of the building cool with night-time ventilation (chapter 8).
- Neither horizontal nor vertical fixed fins, nor a combination, will provide complete shading to windows facing East or West without also completely obscuring the aperture. This will significantly reduce daylight penetration.
- East and West elevations could benefit from moveable shading systems if there is no alternative location for the glazing.
- Meshes are only as good as the 'free area' of the mesh. 50% free area will only reduce 50% of the solar radiation. However, they are useful in allowing views through the mesh. Below 35% 'free area'

the view through a mesh is perceived as obscure.

### Solar control glazing.

This is discussed in the chapter on daylighting. For most types of tinted or reflective glass, both the daylight and solar radiation passing through is reduced. With the exception of High Performance glass (a Pilkington product) more useful daylight is blocked than long wave radiation. It is more energy efficient to reduce the area of plain glass rather than use a larger area of tinted glass that allows the same amount of light in.

### References

Givoni, B (1994), *Passive and Low Energy Cooling of Buildings*. International Thompson Publishing Inc.

Littlefair et al (2006) *Design for improved solar shading control*. Chartered Institution of Building Services Engineers.; Great Britain. Dept. of Trade and Industry. London

Hawkes, D, McDonald, J, Steemers, K (2002) *The Selective Environment: an approach to environmentally responsive architecture*. Spon Press. London

# COOLING BY LANDSCAPE

The most effective method of reducing the cooling load of buildings is by protecting them from solar radiation. Landscaping is a low-cost option with minimal operational costs. This has been the traditional manner of cooling buildings in warm climates ( Figure 7.1). However, modern developments have resulted in buildings that have little natural shading and a significant amount of hard and impermeable surfaces around them. The lack of vegetation around buildings has contributed to a ‘heat island’ effect that has resulted in higher temperatures where land uses are ‘man-made’ (Shudo et al. 1997).

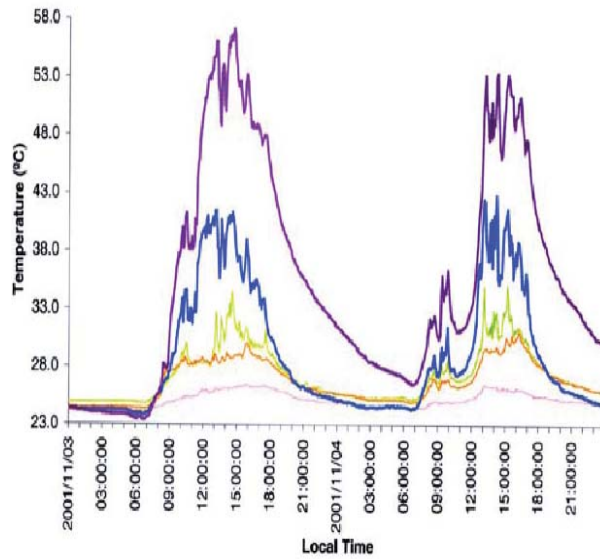

**Figure 7.1**  
A shop-house in the tropical city of Malaca. The ground cover and trees effectively air-condition the building.

**Figure 7.2**  
The impact of vegetation and ground cover on urban temperatures in warm climates. Test results over 2 days showing how trees and shrubs can maintain comfortable external temperatures (28°C) temperatures while hard surfaces reach unbearable (50°C) temperatures.

### Methods of Cooling

Landscaping can reduce cooling loads of buildings in several ways:

- \* Tall trees and climbing plants, trained to grow in selected ways, can provide shade to walls, windows and air conditioning condensers. For example Figure 7.3.
- \* Plants near to buildings reduce the air temperature immediately around the buildings
- \* Plants that cover the ground near buildings reduce direct and indirect radiation from the ground.

Plants achieve cooling in two separate ways:



Figure 7.3

An example of a green wall.

Climbers shade the facade from direct sunlight and cool by transpiration.

firstly, by shading buildings and external areas from direct radiation from the sun. Ground cover will also 'shade' buildings from indirect long-wave radiation from the ground. Secondly, by a process of evapotranspiration. As  $\text{CO}_2$  is absorbed for photosynthesis, water vapour is simultaneously lost through the leaves to the environment. This process (transpiration) cools the leaves by evaporation. Cooling the leaves cools the surrounding air.

### Measured Temperature Reductions.

Shashua & Hoffman (2000) studied the effect of tree planting in various urban locations (avenues, squares, gardens and streets). They found that significant areas of planting in cities had an average cooling effect of  $2.8^\circ\text{C}$  immediately around the planting and that the effect diminished exponentially until it had no effect after about 100 metres. They also found that the hotter the background temperature (outside the planting) the more effective the planting became. They predicted that in hot climates trees could reduce temperatures by up to  $6^\circ\text{C}$ .

Parker (1989) carried out research into the effect of climbing vines on walls. It was found that the surface temperature of a wall was reduced by about  $10^\circ\text{C}$  to  $12^\circ\text{C}$  due to the effect of the shading and transpiration from leaves. Parker (1983) also measured the effect of landscaping on cooling a pre-fabricated lightweight buildings. Electricity consumption for air conditioning

was compared, on days with similar weather conditions, before and after landscaping. It was found that the landscaping almost halved the electricity consumption. McPherson et al. (1989) compared the temperature of rock surfaces with grass surfaces around a building. At mid-day the rock surface was 15°C greater than the turf surface. At a height of 0.5m, the turf was about 2°C lower than the rocks. The grass 'shaded' the long-wave radiation from the ground and reduced the air temperature by transpiration.

### Green Roofs.

A more recent trend has been to construct 'green roofs' where grass or shrubs are planted to cover flat roofs. These types of roofs fall into two categories:

- \* Roofs with deep soil conditions (typically 300mm deep) that can grow shrubs.
- \* Shallow soil conditions that can sustain only small plants or turf.

The problem with 'deep soil' conditions is the additional load on the roof structure particularly if the soil is saturated after heavy rain. This type of roof would require good drainage and lightweight soil or compost with a pumice base.

Ttakakura, Kitad & Goto (2000) studied the cooling effects of roofs. They concluded that the cooling effect was closely correlated to the amount of shading created by the leaves (Leaf Area Index). Without any planting



Figure 7.4

### Green roofs for cooling.

Only when there is dense foliage will green roofs have an impact on cooling load.

(LAI=0) solar gains on the roof resulted in a cooling load. With dense foliage (LAI=3) evapotranspiration significantly reduced the cooling load on the roof structure beneath. They also found that the more solar gain, the greater the effect of cooling.

However, well insulated roofs with reflective surfaces are a more economical and cost-effective means of reducing solar radiation through a roof.

## References.

H Shudo et al. (1997), A Study of Temperature Distributions Influenced by Various Land Uses. *Energy and Buildings* 26, pp 199-205.

L Shashua & M Hoffman (2000) Vegetation as a Climatic Component in the Design of an Urban Street. An empirical model for predicting the cooling Effect of Urban Green Areas with Trees. *Energy and Buildings* 31 pp 221-235.

Parker, J.H. (1989). The Impact of Vegetation on Air-Conditioning Consumption. Proceedings, Conf on Controlling the Summer Heat Island. Lawrence Berkeley Laboratory, CA. LBL-27872, pp 46-52

Parker, J. H (1983). The Effectiveness of Vegetation on Residential Cooling. *Passive Solar Journal*, pp 123-132

McPherson, E al. (1989). Effect of Three Landscape Treatments on Residential Energy and Water Use in Tuscon, AZ. *Energy and Buildings* 13 (2) pp 127-138

T. Takakura, S. Kitad & E Goto (2000). Cooling Effect of Greenery Cover over a Building. *Energy and Building* 31 pp 1-6

# COOLING BY NATURAL VENTILATION

## The Problem of Air-Conditioning

There has been an increasing trend in New Zealand to air-condition buildings. Air-conditioned buildings are generally sealed and the constant, cheap supply of electricity has allowed cooling plant to modify the climate within the building while the architecture pays little attention to the environment or energy consumption.

With an insecure and significantly lower supply of

electricity in the future combined with increasing temperatures due to global warming, fully air-conditioned buildings will, at best, be disproportionately expensive to operate and may even become unusable if electricity supplies are not constant. Buildings that are naturally ventilated, along with other design measures, will remain both economical to operate and have the ability to remain in operation without an electrical supply. Furthermore, occupants will gradually adapt to a warmer climate and accept increased temperatures.

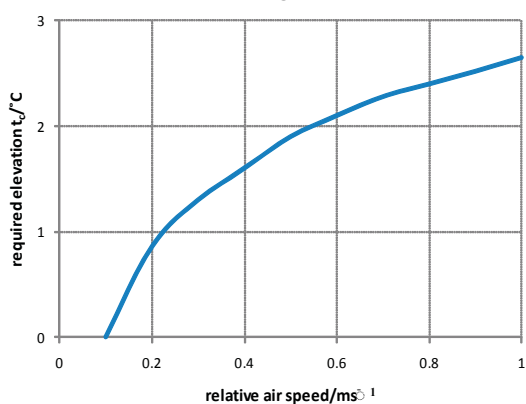

**Figure 8.1**  
The Effect of Air Speed on Perceived Temperature.

The graph shows that very little air speed is required to achieve a 1°C cooling effect. It is not possible to achieve more than a 3°C cooling effect at acceptable indoor wind speeds.

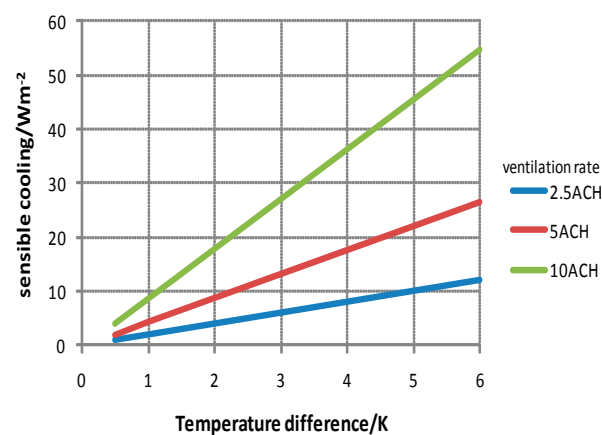

**Figure 8.2**  
The Cooling Capacity of Air

Typical offices have internal heat gains (people + equipment) of 15-30 W/m<sup>2</sup>. When the outside air is 3°C cooler than inside, a natural ventilation rate of between 5-10 air changes per hour is required to remove the heat generated. This is easily achieved by natural ventilation.

Natural Ventilation as an Alternative to Air-Conditioning

Natural ventilation in buildings provides two main functions:

- 1) To provide reasonable standards of air quality and
- 2) To provide cooling when needed.

The amount of ventilation required to provide air quality is almost insignificant in comparison with the amount of ventilation required for cooling. In most cases natural ventilation for cooling is an alternative to air-conditioning. The advantages are that it does

not consume energy nor contribute to CO<sub>2</sub> emissions. The disadvantage is that it does not achieve constant environmental conditions. However, provided other characteristics of the building can control heat gains, natural ventilation can provide comfortable and reasonably controllable conditions for building occupants.

The cooling capacity of air is limited (Figure 8.1) and, therefore, this method of cooling is only likely to be successful if all other heat gains have been reduced to a minimum. For example, natural daylight can displace artificial lighting and solar shading limits solar heat

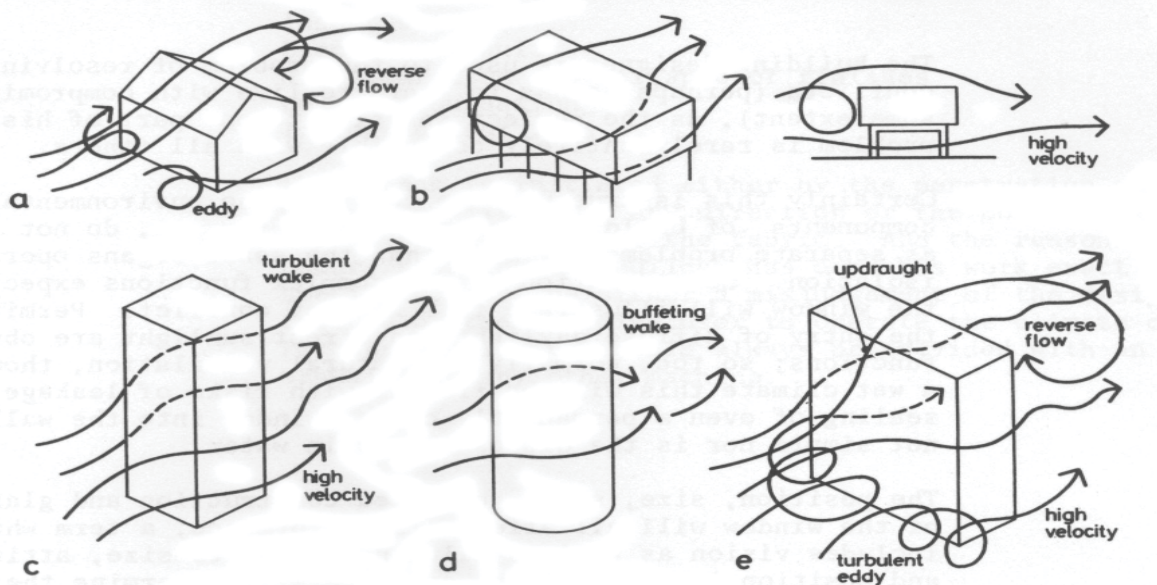

Figure 8.3

Typical examples of how wind passes over different built forms creating a positive pressure on the windward side and a negative pressure on the leeward side.



## COOLING BY NATURAL VENTILATION

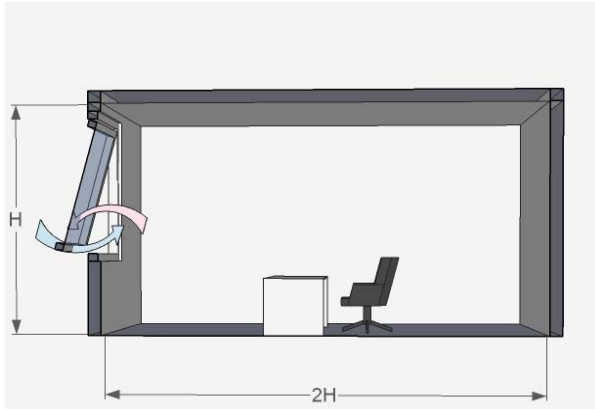

Figure 8.4a

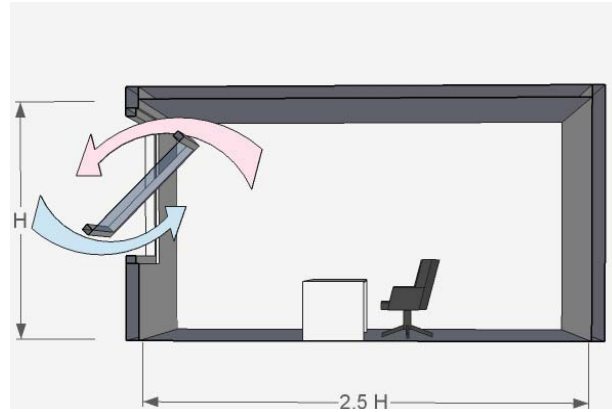

Figure 8.4b

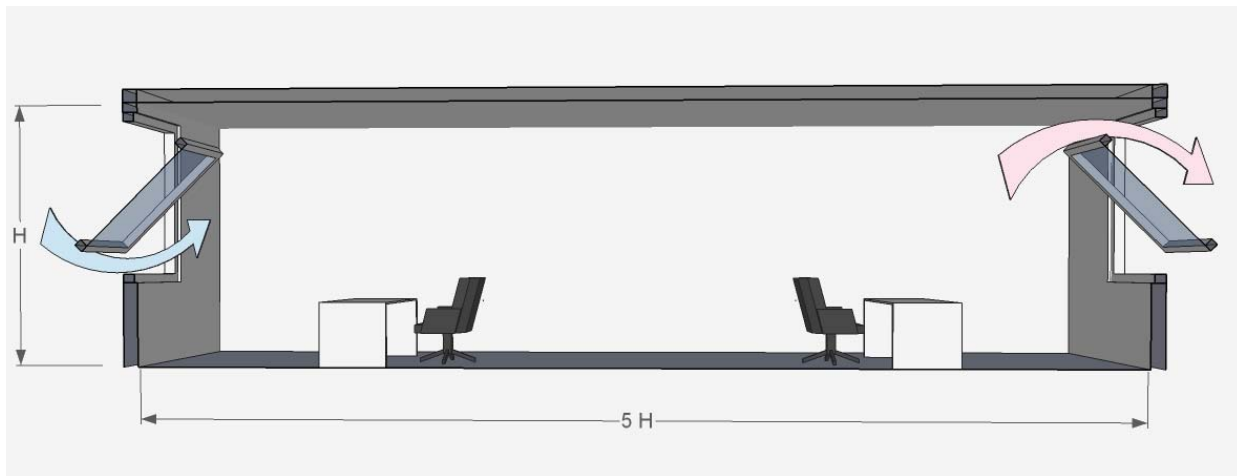

Figure 8.4c

### Maximum room depth for natural ventilation

- Single sided ventilation with sash or top hung windows.
- Single sided ventilation with horizontal or vertical pivot windows exceeding 1.5m in height.
- Double sided ventilation with any window type.

gains. Figure 8.2 shows the relationship between the cooling capacity of air and the number of air changes for given internal/external temperature differences.

As a rule of thumb, natural ventilation can generally meet cooling requirements if the average heat gains (solar and internal) over a day are of the order of 30-40Wm<sup>2</sup>.

To achieve this requires:

- good solar control (solar shading)
- low levels of internal gains (lighting, small power)
- acceptance that peak temperatures may exceed 25°C for some periods of time.

Cooling of buildings by natural ventilation can also increase if the ventilation system is in operation outside occupied times. Night-time cooling takes advantage of lower external temperatures at night-time to cool the structure and lower the radiant temperature in a building. This method is most effective if the building has a high thermal mass.

### The Basics of Natural Ventilation

Natural ventilation is driven by two distinct forces within a building:

1) A difference in pressure from one side of a building to another caused by the wind. Figure 8.3 shows typical examples of how wind passes over different built forms

Figure 8.5  
Ventilation performance of common window types.



Sliding sash windows: maximum opening 50% of aperture. Some buoyancy effect if window exceeds 1.5m in height.

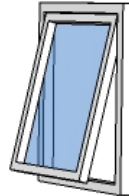

Top hung window: limited opening area, poor buoyancy effect and little wind driven ventilation.

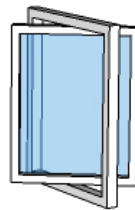

Vertical pivot: reasonable buoyancy effect. Wind driven ventilation is dependent of wind direction.

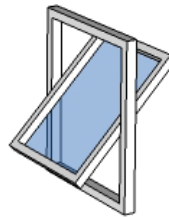

Horizontal pivot: good buoyancy effect if window height exceeds 1.5m and wind driven ventilation.

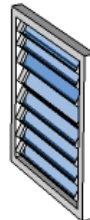

Louvers: reasonable buoyancy effect. Security is good for nighttime ventilation but can cause excessive infiltration in cold weather.

## COOLING BY NATURAL VENTILATION

creating a positive pressure on the windward side and a negative pressure on the leeward side.

2) A difference in pressure due to a vertical temperature difference within a space. This is called buoyancy or the stack effect and is due to hot air rising.

In practice, both of these modes of operation act at the same time. However, the major concern is for providing summer cooling at times when the outdoor

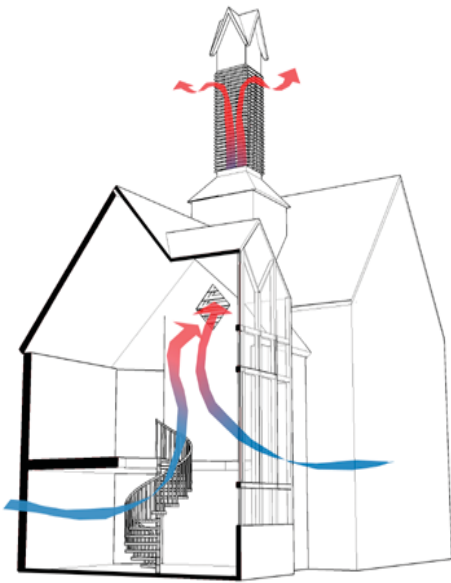

**Figure 8.6**  
**Stack Ventilation**

If air at the top of a stack is warmer than air in a room below then there will be a density difference that draws air into the stack and can draw air across a room.

temperature may be similar to indoors and there may be little wind. In designing building for cooling by natural ventilation the wind cannot always be relied upon and buoyancy effects alone are considered.

### Single Sided Ventilation

One of most common form of natural ventilation is a single window on a single side of a room. This relies on wind turbulence and is limited by the depth of the room. As a rule of thumb, natural ventilation for a room with single sided ventilation is that the ventilation has limited effect when a room is deeper than twice its height (Figure 8.4.a).

With multiple opening on a single side and provided there is a height difference between the openings (Figure 8.5) the ventilation rate can be enhanced by the stack effect and the room depth for effective ventilation can be increased to a maximum of about 2.5 times the height of the room (Figure 8.4b).

### Double Sided Ventilation

With openings on both sides of a room air can flow in on one side and out on the other. The rate will depend on the amount of obstructions in the room and on the ability of the shape of the building to create a pressure difference from one side to the other. This requires open-plan spaces and a narrow floor plan or atrium. The rule of thumb for the maximum distance between facades is 5 times the floor to ceiling height

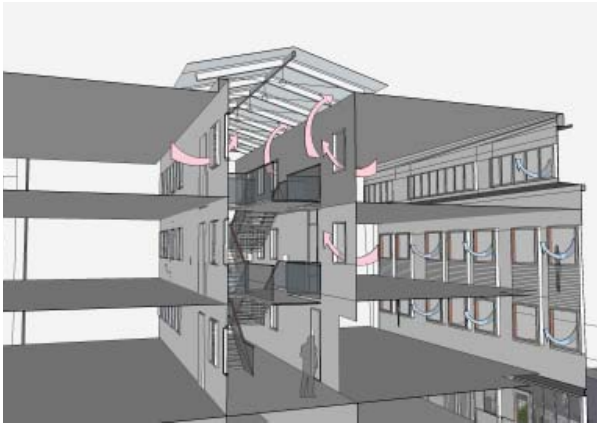

Figure 8.7

### Atrium Ventilation

Air from both sides of a building can be drawn towards a central atrium thereby increasing the plan area that can be naturally ventilated.

of the room (Figure 8.4c).

Some window types are better than others for enhancing the depth of natural ventilation for cooling. These are illustrated in Figure 8.5.

### Stack ventilation

If air at the top of a stack is warmer than air in a room below then there will be a density difference that draws air into the stack and can draw air across a room (Figure 8.6) The same rule of thumb applies for stack ventilation as for double sided-ventilation; it can only draw air from a room depth not greater than 5 times the room height.

The higher the stack height the smaller the outlet

ventilators need to be. In general a stack outlet height should not be less than half the floor to ceiling height of the room it serves.

### Chimney ventilation

Chimney ventilation is a refinement of stack ventilation. The additional height gained by a chimney allows for a smaller outlet or increased speeds of air movement provided the temperature difference can be maintained. Chimneys have a large exposed surface area that can be a disadvantage when cold or an advantage when hot. In cold weather, the temperature in the chimney can be colder than the room. In this case the chimney should either be insulated or a damper introduced to stop the down flow of air. In hot weather the chimney can be heated by solar gains and increase the temperature difference. This can be further enhanced by glazed elements in the chimney to increase solar radiation capture.

An advantage of a solar chimney is that it can be located away from the room it serves and placed on the sunny side of a building in order to capture solar radiation. A further refinement of the chimney is to install fans to pull air through the building on hot days still days.



### Atrium ventilation.

Atrium ventilation (Figure 8.7) is a variation on the chimney ventilation principle. The advantage of the atrium is that it can draw air from both sides of a building towards a central atrium thereby increasing the plan area that can be naturally ventilated. The atrium also allows daylight to enter into, what would be otherwise, a deep plan building.

### Double skin facades.

A double skin facade is where an additional layer of glass is placed, usually 600 to 900mm, out along the length of a facade. Solar heat gains are trapped within the cavity and can either be used to heat a building or ventilated out at the top to cool a building. In this mode it has a marginal cooling effect but is only of benefit in a naturally ventilated building.

A further sophistication is to use the double skin as a solar chimney that draws air from the occupied spaces. Sometimes known as 'shaft-box facade' this mode provides a practical means of inducing strong natural ventilation in tall buildings.

In cooler climates, this method can also be used to heat the building in cold weather (Figure 8.8).

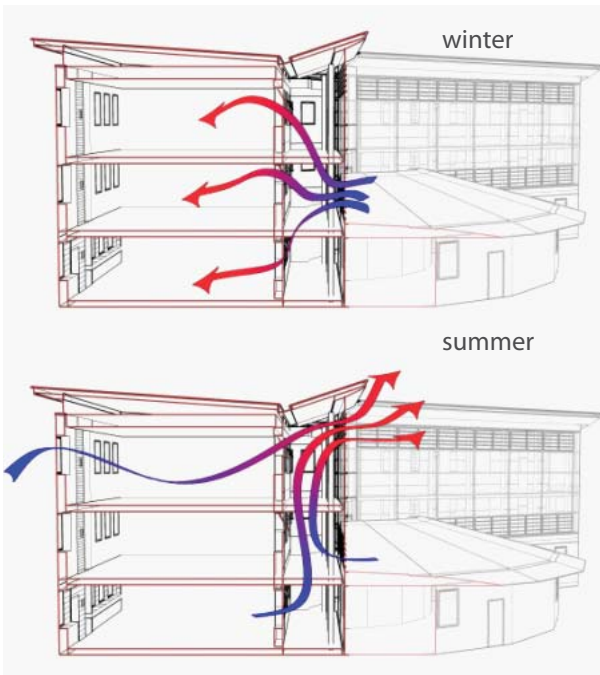

Figure 8.8  
Double Skin Facade

The double skin can be used to cool in the summer by drawing air up through the shaft or warm during winter by trapping solar heat gains.

## Night-time ventilation

Night ventilation is a method of continuing the operation of an existing ventilation system during cooler night temperatures so that it can assist in cooling a building. In temperate climates where there is a significantly lower temperature at night, cool air can be drawn through a building at night with several advantages:

- Lower external night-time temperatures increase the stack effect thereby enhancing the cooling effect.
- The temperature of the structure in a building can be reduced which improves thermal comfort.
- High rates of ventilation at night do not cause draughts or noise problems.

## Controlling Natural Ventilation

In temperate climates the need for natural ventilation to cool in the summer compared with a minimal amount required in the winter can result in a tenfold difference in the requirement for ventilation. This wide range requires careful control of apertures that perforate the building.

Some automation may be required for controlling the apertures. In this case consideration should be given to position of sensors and whether actuators should simply be open/closed or infinitely variable.

## References

De Dear, R. (2006) Adapting buildings to a changing climate: but what about the occupants? *Building Research & Information* Volume 34, Issue 1, January 2006, pages 78-81

CIBSE (2005) *Natural ventilation in non-domestic buildings*. Chartered Institution of Building Services Engineers. London

# COOLING WITH THERMAL MASS

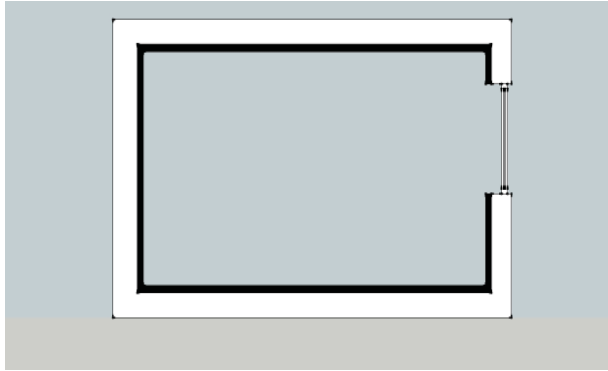

**Heavyweight:** exposed solid ceiling and floor, solid internal walls and less than 50% glazing. Thickness of solid materials has minimal effect when exceeding 50mm.

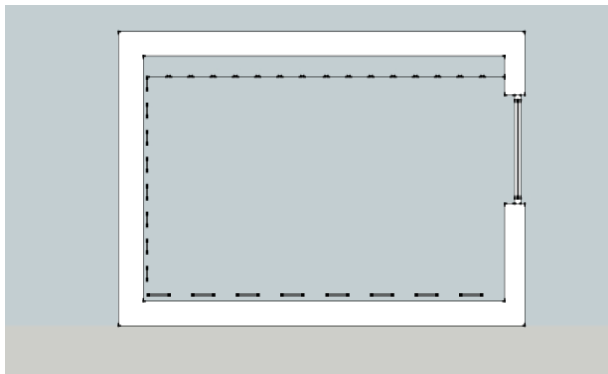

**Lightweight:** suspended ceiling, carpeted or raised floor, linings to internal walls and more than 50% glazing.

**Figure 9.1**  
Lightweight and heavyweight construction

## Thermal mass to enhance cooling

Thermal mass is a means of storing energy. It can store heat from solar energy and delay the re-radiation of the heat over a longer period of time. This is useful for housing where there is a heat demand in the evenings.

Thermal mass can also be used to maintain buildings at lower than ambient temperatures by cooling the mass of the internal building fabric. This is usually applicable to non-domestic buildings where they are cooled over-night, generally by natural ventilation, in order to compensate for heat gains the following day. This chapter will focus on the use of thermal mass to enhance cooling.

## Thermal mass within a building

Thermal mass is generally part of the structure and envelope of a building and needs to be a dense material such as concrete, brick or rock. For maximum effectiveness it needs to be evenly distributed within spaces for two reasons. Firstly, the mass needs to be 'coupled' to a space so that heat transfer (from building material to air) can be carried out over a large area. As a rule-of-thumb, dense materials with

a thickness greater than about 50mm have little additional benefit in reducing daily temperature cycles. Secondly, thermal mass that is lower than ambient temperature is perceived as cool due to its low radiant temperature. The larger this cooling surface is, the greater the perception of a lower temperature.

The massive material also needs to be exposed to a space and not be covered by lightweight materials. For example, the effect of the thermal mass of a solid concrete floor is practically eliminated by a carpet and likewise a suspended ceiling can cancel out the mass of a concrete ceiling above (Figure 9.1). Thermal mass can be embodied in the internal walls and partitions of a building. High proportions of glazing in external walls will significantly reduce the thermal mass of a building.

The position of the thermal mass is also important when considering direct solar gains. If windows cannot be completely shaded at the time when solar gains are unwanted, then thermal mass should be located where the 'sun-patch' is in a room. The colour of the material will also have an impact on its ability to absorb and re-radiate long-wave radiation. Dark, matt coloured materials absorb and re-radiate more effectively than light, shiny materials.

Figure 9.2 indicates the effect of thermal mass in

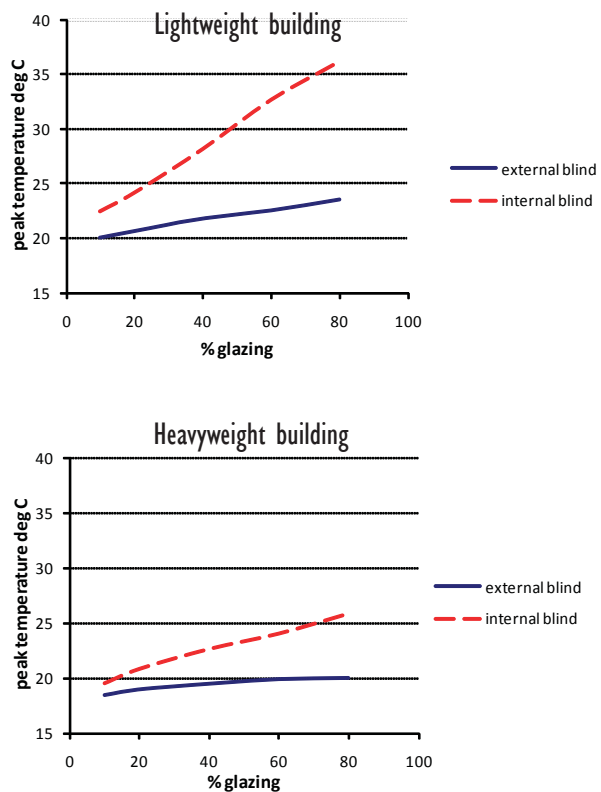

Figure 9.2  
Comparison of Peak Temperatures in Lightweight and Heavyweight buildings.

Comfort conditions in lightweight buildings with internal blinds and glazing over 50% can only be achieved with air-conditioning. Heavyweight buildings with external blinds do not require air-conditioning.

Adapted from: Loudon, A.(1968) Summertime Temperatures in Buildings. BRS Current Paper 47/68



## COOLING WITH THERMAL MASS

reducing temperatures with differing shading devices and proportions of glazing.

### Mass and night-time ventilation.

For passive cooling, thermal mass is of greatest benefit when employed with night-time ventilation. Figure 9.3 indicates the effect of thermal mass on internal temperatures. The figure indicates two important features of thermal mass:

- 1) It reduces peak temperatures.
- 2) It can delay the time of peak temperature to outside the occupied hours of the building.

The efficiency of the air as a cooling medium can be

increased by not only passing it over surfaces within a room but also within the building structure. A typical example is a hollow concrete floor or ceiling where cool air is passed through the hollow cores and ducted to a room.

a labyrinth of heavyweight ducts below the floor. In the daytime, the fresh air supply is brought in through the same ducts and cooled before entering the space.

### Thermal mass outside a building.

To enhance thermal mass within a building or, where adequate thermal mass cannot be achieved, mass outside the building can also be employed. This is

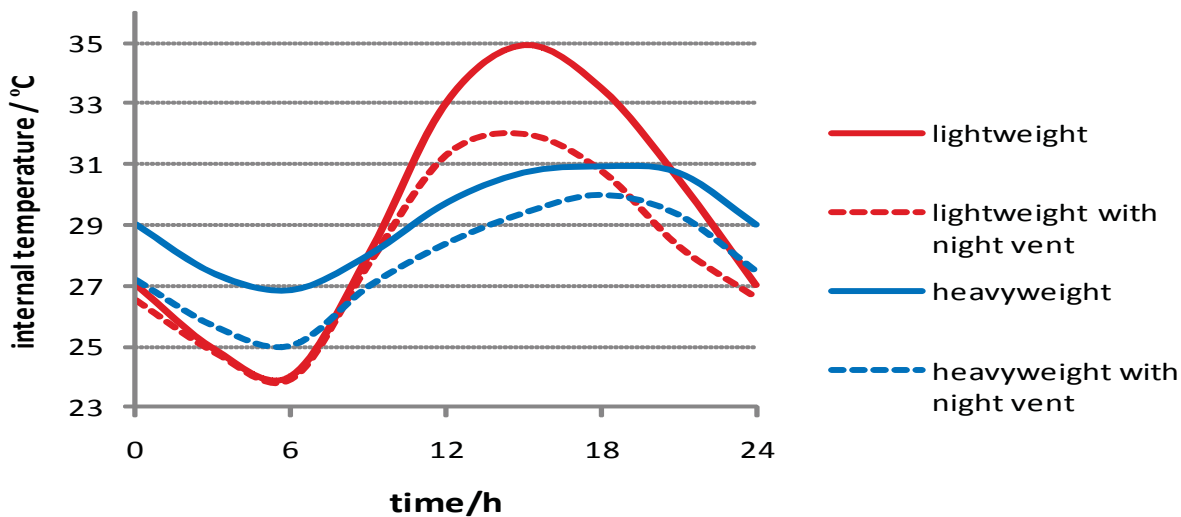
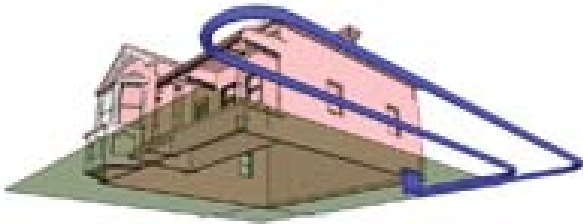

Figure 9.3

### Night-time cooling in heavy and lightweight buildings

Heavyweight buildings can be at least 3°C cooler and the peak is outside hours of occupation.

generally less effective since there will be no benefits from lower radiant temperatures in the building. However, ducts within the ground outside can be used for night-time cooling (Figure 9.4). If the ducts are of sufficient length and the material adequately coupled it can be an effective system for both diurnal and seasonal cooling and heating.



**Figure 9.4**  
**Utilising Thermal mass Outside a Building**  
 Ground ducts or pipes into bodies of water, soil or rock can be used to cool buildings.

### Phase Change Materials.

The change of phase of a material means it changes from a solid to a liquid or from a liquid to a gas. Due to the re-arrangement of the molecules, it involves a considerable amount of energy. This is illustrated in Figure 9.5. For use in buildings, PCMs are made of waxes or salts that change their phase at about 24°C.

As the room temperature increases above 24°C, heat

flows into the PCM causing it to melt, instead of causing the air to heat up further. If there were sufficient PCM to continue to melt until the peak heat input was past, overheating can be prevented. (Qureshi et al 2011).

PCM is behaving as thermal mass, but because of the large amount of heat involved, it is very “concentrated”. For example a 10mm layer of PCM material has the effect of about 50mm of concrete.

**Heat storage of sensible and latent heat storage devices**

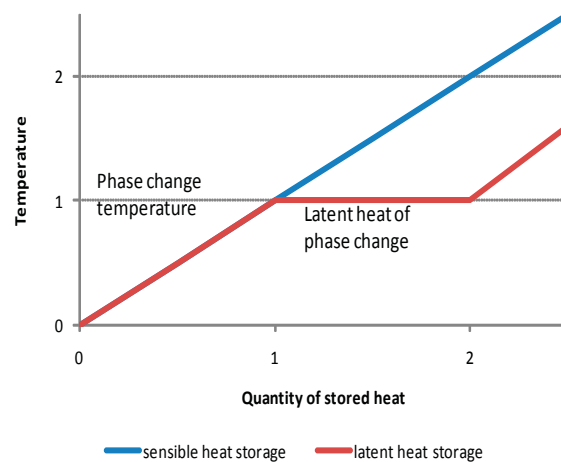

**Figure 9.5**  
**Principles of Phase Change Materials.**

As soon as phase change commences (melting) heat is absorbed without raising the temperature.

## References

Baker, N & Steemers, K. (2000). *Energy & Environment in Architecture*. E & FN Spon

Givoni, B (1994) *Passive & Low Energy Cooling of Buildings*. Van Nostrand Reinhold.

Loudon, A. (1968) *Summertime Temperatures in Buildings*. BRS Current Paper 47/68

Qureshi, W, Nair, N, Farid, M (2011) Impact of energy storage in buildings on electricity demand side management. *Energy Conversion and Management* 52 (2011) 2110–2120

# ESTIMATING THE ENERGY PERFORMANCE OF BUILDINGS

## The Conflicting Requirements of the Building Envelope

The previous chapters have studied the properties of buildings that can reduce energy demand and CO<sub>2</sub> emissions from a building: shading, daylighting, ventilation and so on. There will always be conflict when implementing these properties in a design. For example, good daylighting requires a large area of glass. But large areas of glazing result in disproportionately

large heat loss and can also lead to high levels of solar heat gain. These factors need to be balanced for an optimum level of glazing.

This chapter reviews how to achieve a reasonable balance and what the implications are for the design of buildings. Some simple rules of thumb will guide designers at the early stages of design.

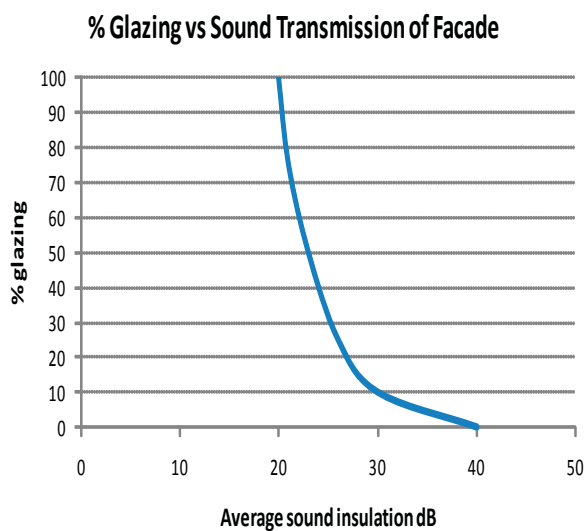

Figure 10.1

% glazing in relation to sound transmission through a facade.

The graph indicates the sound transmission for a building with lightweight walls and single glazing. With double glazing, the curve becomes almost vertical.

Adapted from: British Standard Code of Practice CP153 Part3, 1971. Windows and roof lights-sound insulation.

**% glazing vs. satisfaction with adequate view out of window**

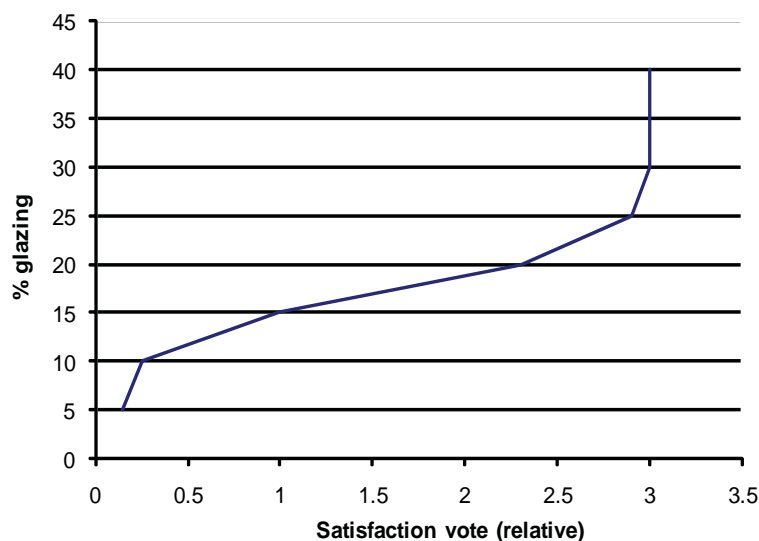

**Figure 10.2**  
% glazing in relation to views out

Satisfaction of views out of a room dramatically reduce when the proportion of glazing falls below 10%. Over 10% and the satisfaction grows gradually. However, there is virtually no increased satisfaction with glazing over 30%.

Adapted from Keighley, E. C. (1973) Visual Requirements and Reduced Fenestration in Offices. Building Science Vol 8. pp321-331

### Percentage Glazing on a Facade.

One of the most important rules-of-thumb for the environmental design of a building is the proportion of glass on a building facade (% glazing). Glass is the 'weak-link' in the environmental performance of a building as it is the most significant route by which energy enters or leaves the building envelope. All visible energy (daylight) comes through windows, almost all solar heat gains come through windows and a given area of window loses almost 10 times more energy through it than a similar area of insulated wall. The proportion of glass is also a good indicator of the sound insulation properties of a facade (Figure 10.1)

and also the perception of 'view' through fenestration (Figure 10.2).

Before looking at the optimisation of these conflicting requirements, it is important to define the measurement of % glazing. Figure 10.3 indicates some typical examples of facades with different % glazing that is calculated from the ratio of:

$$(\text{the area of glass} : \text{area of the facade}) \times 100 = \% \text{ glazing}$$

The area of glazing can be measured either internally or externally. However, the area of facade is measured internally. Floor-to floor thicknesses are not included and window frames are measured as part of the

glazing area. As will be shown below the overall level of accuracy does not merit detailed measurement; + or - 5% is adequate for the purpose.

**Balancing the energy flows through the building fabric.**

Energy flows into and out of a building and most of this is through windows. Energy flowing in is made up of both solar energy in the visible spectrum (daylight), that can displace the need for artificial lighting, and also heat from solar energy that may either be useful by contributing to a heating need or it could be unbeneficial and contribute to overheating.

Over a year these flows of energy will vary. There may be a heating load in the winter and a cooling load

in the summer. The amount of electrical energy that daylight can displace depends on the level of artificial lighting required and will vary over the day as well as the seasons. Cooling load will depend not only on the time of year but also on internal heat gains and the orientation of the glazing.

These can all be balanced by plotting the energy for the individual requirements for heating, lighting and cooling against % glazing for given orientations and required light levels. The method is based on the 'LT Method' ( Baker & Steemers 1994) which makes many assumptions about such things as thermal mass, and control systems for mechanical plant. However, the analysis gives a useful overview of the issues and provides some important rules-of-thumb.

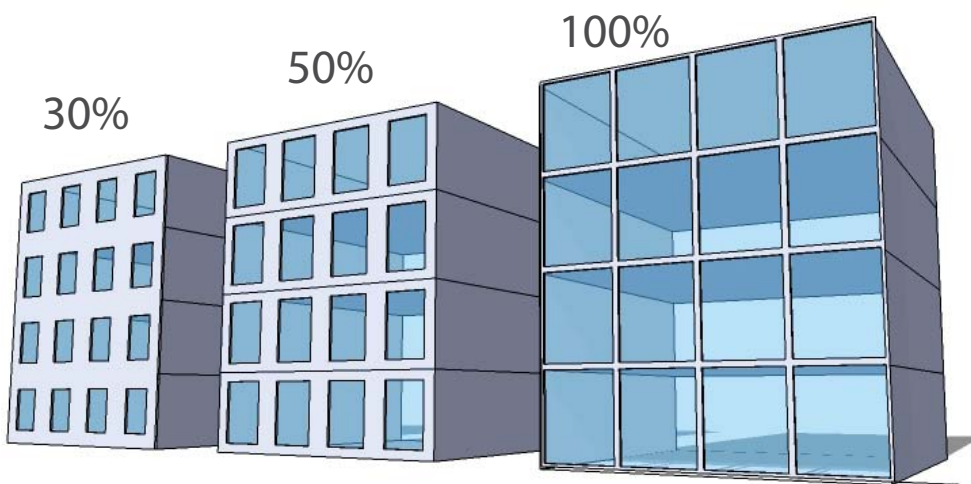

**Figure 10.3**  
Examples of buildings with different % glazing

The area of facade is measured internally. Floor-to-floor thicknesses are not included and window frames are measured as part of the glazing area.

Daylighting:

The more glass in a facade, the more daylight will enter a room. However, the relationship is not necessarily linear. In offices or educational environments, where there is a significant amount of furniture, glazing below the working plane (generally taken as 0.85m high) renders a significantly less contribution of daylight than glazing above the working plane. Ironically it is also this low level glazing that tends to collect unwanted solar gains and contributes least to views out. Glazing below the working plane has few environmental benefits.

Figure 10.4 is a graph that relates the % glazing to the minimum daylight factor in a room for single sided glazing. This can be used for calculating the area of glass required for given room dimensions and Daylight Factor. The dark line indicates that, for a 2.5% DF in a room that is 2.75 deeper than its height (8m deep typical office), 80% glazing is required.

For example, the New Zealand Green Building Council gives credits for daylight levels:  
 1 credit for a min.2.5% DF over 30% of the floor area  
 2 credits over 60% of the floor area and 3 credits

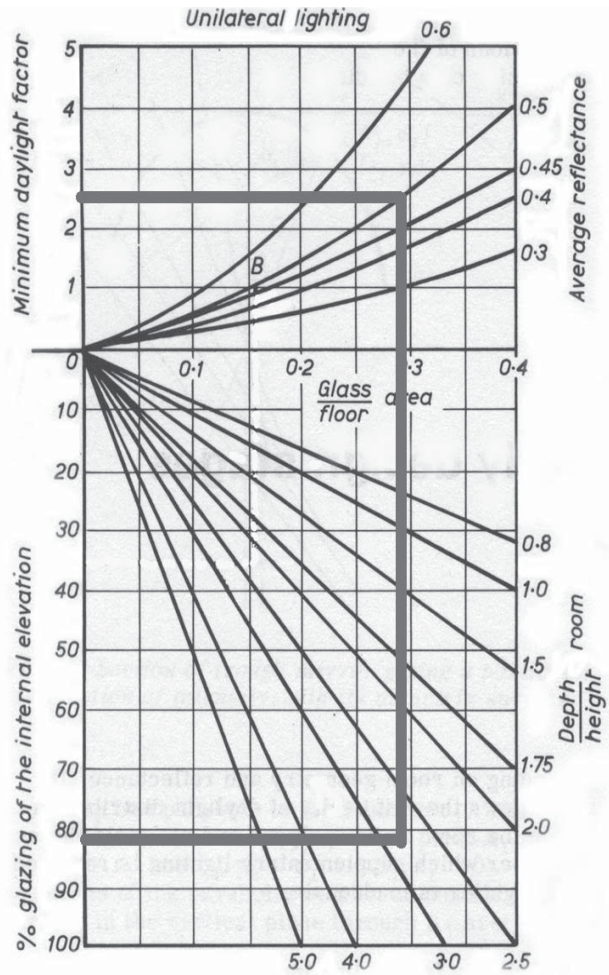

Figure 10.4  
 % glazing vs Daylight Factor

A simple graphical method for relating the amount of glazing required to achieve a given Daylight Factor.

Source; Byrd, H. & Hildon, A (1979) Daylighting: appraisal at the early design stages. LR&T Vol. 11 No.2

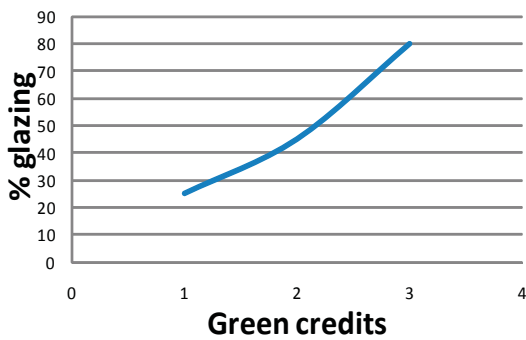

Figure 10.5

Achieving Green Credits (NZ Green Star) requires an exponential amount of glass

for 90%.

Figure 10.5 indicates that there is an exponential relationship between increasing the DF and the area of glass required to achieve this.

### Heat Loss

Glass is a poor insulator and the rate at which heat is lost through double glazing is typically 10 times the rate of heat loss through well insulated building fabric.

The performance of glass can be marginally improved by applying a coating (“low e”) to a face of the glass. This coating effectively enhances the ‘greenhouse effect’ of the glass by reducing the rate at which long-wave radiation can escape.

The overall rate of heat loss on a building facade is

directly proportional to the area of glazing. However, depending on the times of occupation and type of building, the energy balance between useful solar heat gains and heat losses will vary. In commercial buildings, where there are significant internal heat gains and occupation is during the day, solar heat gains are of limited benefit in a temperate climate and contribute to the risk of overheating in sub-tropical climates.

### Overheating

Overheating within a building is caused by two main factors:

- 1) internal heat gains from people, lights and equipment,
- 2) heat gains from solar radiation.

Figure 10.6 indicates the relationship between overheating due to solar radiation, the proportion of glazing and types of shading devices. The graphs not only indicate the need for additional cooling but also the effectiveness of shading devices. Note the difference between external and internal blinds. Internal blinds are of little benefit in combating excessive solar heat gain. The important implication of these graphs is that only complete external shading of glass is likely to keep peak temperatures within the comfort zone for typical proportions of glazing.

For 30% glazing or more, some form of cooling is required for buildings with either internal or no



**% Glazing vs peak temperature**

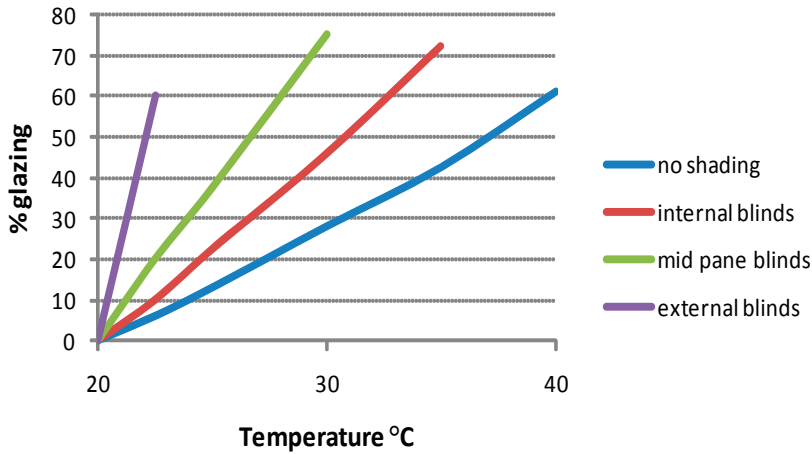

Figure 10.6  
% glazing and overheating.

Note the difference between external and internal blinds. Internal blinds are of little benefit in combating excessive solar heat gain.

Adapted from: Loudon, A.(1968)  
Summertime Temperatures in  
Buildings. BRS Current Paper 47/68

shading devices.

**Balancing the conflicting impacts of glazing.**

Figure 10.7 compares the conflicting requirements for glazing by relating daylight, heating and cooling to annual energy use. The graphs show each of these individually as well as the total. The graph is for a building in a temperate climate in the southern hemisphere and for the North elevation.

**Energy for lighting.**

The curve for lighting energy decays gradually. Daylight displaces the need for artificial lighting. However, after about 40% glazing, there is little extra benefit as glazing below the working plane has little contribution

and daylight cannot usefully penetrate into a room more than about twice the height of the room (Figure 4.3)

**Energy for heating.**

The curve is almost flat. In temperate climates on orientations facing North, East and West there is generally a balance between heat loss and useful solar heat gains.

**Energy for cooling.**

For unprotected glass, the curve rises linearly with the proportion of glass.

**Total Energy use.**

When the energy implications for heating, lighting and cooling are all combined, it is clear that there is an optimum proportion of glazing.

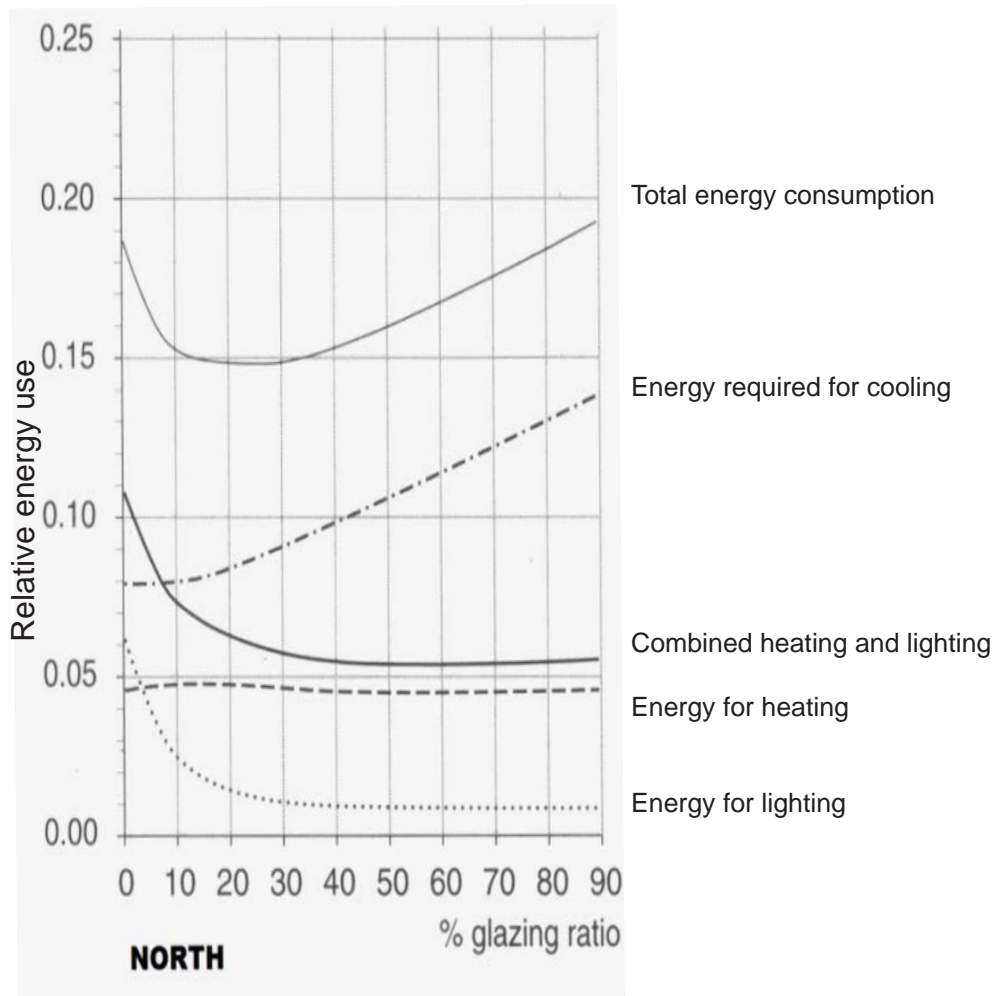

Figure 10.7  
 The relationship between % glazing and the energy performance of the building.  
 Lighting level required inside: 150 lux.

As % glazing increases:

- lighting energy decreases exponentially until 40% glazing when there is little benefit in more glass.
- heating energy remains much the same
- cooling energy increases linearly
- total energy is reduced to a minimum when the glazing is about 20-30%.

### Optimising the Building Envelope

The following sets of graphs (Figure 10.8) illustrate the energy consumed by a typical building that is occupied during the day only. The lines illustrate the annual energy requirements of the building for various % glazing. The graphs are in sets that illustrate optimum proportions of glazing for various orientations. The curves are in the same codes as Figure 10.7

The graphs are adapted from the LT Method (N. Baker, K.Steemers 1994) and assume a ceiling height of about 3m and that the set point for heating and cooling is 20°C. The windows are double glazed and the building fabric is well insulated.

It should be noted that the combined heating and lighting load curve (see Figure 10.7) should not be read as net energy consumed if there is no air-conditioning. Additional energy will be required for mechanical ventilation in certain circumstances.

The most emphatic thing that the graphs illustrate is that, irrespective of the light levels, internal heat gains and orientation, the optimum % glazing never exceeds 50%. As a simple rule-of-thumb, the amount of glazing in any circumstance should not exceed 50% glazing. The optimum for roof lighting (horizontal) is 10%.

Figure 10.9 illustrates the optimum 5 glazing for

Figure 10.8

Total annual energy consumption for different orientations on a typical office building in relation to % glazing.

Artificial Lighting Level of 150 Lux

Internal heat gains of 15 W/m<sup>2</sup>

For any orientation, the optimum % glazing is of the order of 20 to 30%.

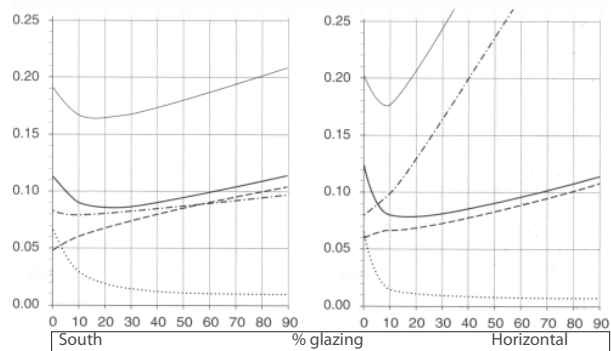
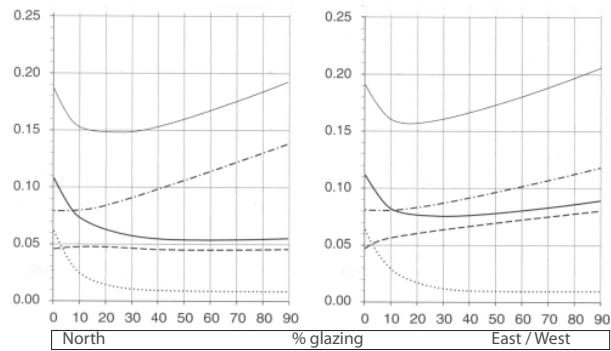

# ESTIMATING THE ENERGY PERFORMANCE OF BUILDINGS

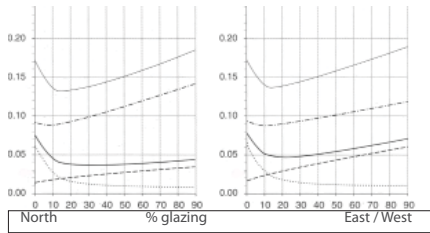

150 Lux 30 W/m<sup>2</sup>

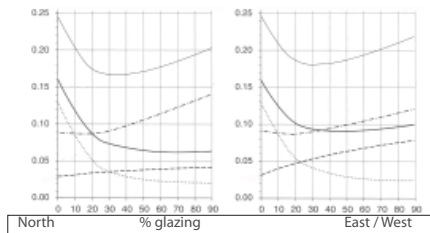

300 Lux 15 W/m<sup>2</sup>

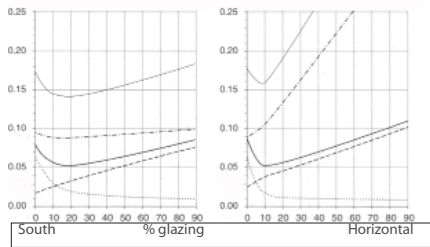

150 Lux 15 W/m<sup>2</sup>

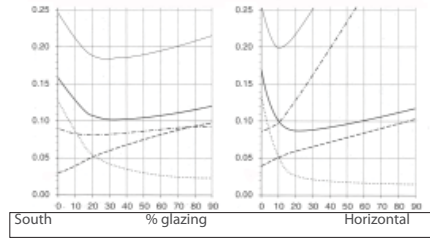

300 Lux 15 W/m<sup>2</sup>

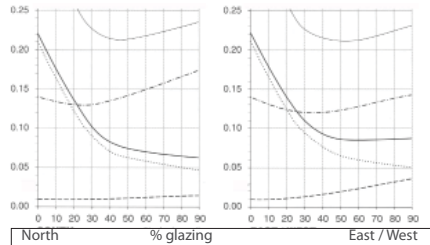

300 Lux 30 W/m<sup>2</sup>

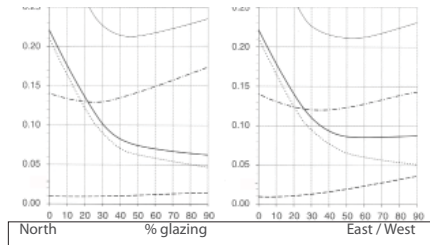

500 Lux 30 W/m<sup>2</sup>

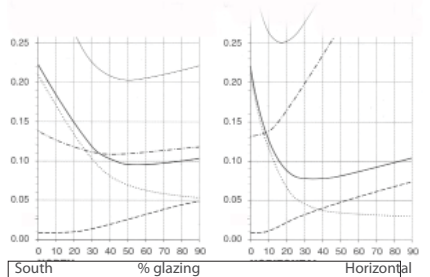

150 Lux 15 W/m<sup>2</sup>

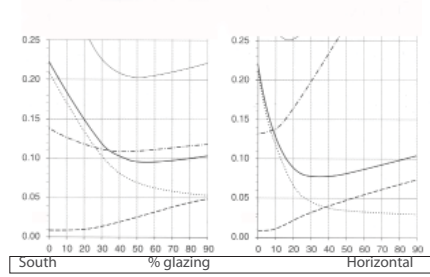

300 Lux 15 W/m<sup>2</sup>

**Figure 10.9.**  
The optimum area of glazing for all conditions (temperate climate).

almost all conditions of orientation, lighting levels and internal heat gains.

Each graph is for different values of light level required ( Lux) and different internal heat gains ( $W/m^2$ ). 150 Lux is a low level and 500 Lux is very high (see chapter on Low Energy Lighting Systems).

$15W/m^2$  is a low internal heat gain and  $30W/m^2$  is high.

The simple rules-of thumb that can be derived from these graphs are:

- 1) The optimum area of glazing varies very little with orientation
- 2) The optimum % glazing is one tenth of the lighting level required internally. For example, a requirement of 400 lux as an internal light level (NZ Green Building standard) results in an optimum % glazing of 40%.
- 3) Every 10% increase in glazing above the optimum results in a 5% increase in energy use
- 4) There are no normal conditions where a glazing proportion of more than 50% is effective.

### Sub-tropical climates

The above graphs are for a temperate climate and assume heating degree-days of 2450 which is within Zone 2 of NZS 4281. Applying these graphs to Zone 1 would result in a additional cooling load and reduced heating load. Since the heating load is less sensitive to %glazing than the cooling load, the optimum glazing

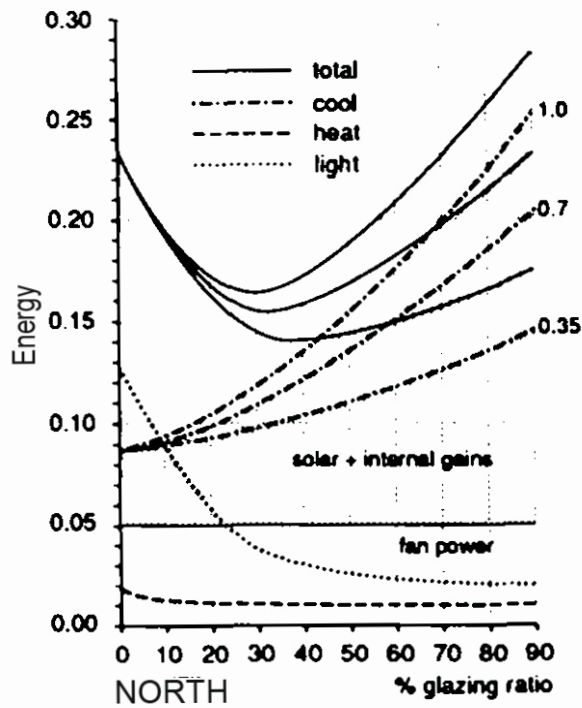

Figure 10.10  
Optimum % glazing in sub-tropical climates with shading

The curves are the same as those in Figure 10.7 except that there are 3 options for shading, that impact on the cooling load. '1' indicates no shading device. '0.7' indicates a shading device that also cuts out daylight. '0.35' indicates a device that shades but does not cut out daylight..

See Figures 4.5 and 6.3 for examples

Source: Baker, N. & Steemers, K. (1996)

## ESTIMATING THE ENERGY PERFORMANCE OF BUILDINGS

would shift slightly towards a lower proportion of glazing. This is illustrated in Figure 10.10 where the impact of shading devices is included. Below 20% glazing, shading devices have little benefit. But this increases exponentially. For example, a well shaded building (0.35) with 40% glazing consumes half the energy of an unshaded building of 80% glazing.

However, with climate change, increased temperatures are likely to shift Zone 2 into Zone 1 and Zone 3 into Zone 2. This would make Zone 1 become sub-tropical.

### References

British Standard Code of Practice CP153 Part3, 1971. Windows and roof lights-sound insulation.

Keighley, E. C. (1973) Visual Requirements and Reduced Fenestration in Offices. Building Science Vol 8. pp321-331

Byrd, H. & Hildon, A (1979) Daylighting: appraisal at the early design stages. LR&T Vol. 11 No.2

Baker, N., Steemers, K. (1994) The LT Method v 2.0, The Martin Centre for Architectural & Urban Studies, Cambridge.

Baker, N. & Steemers, K. (1996) LT Method 3.0- a

strategic energy-design tool for Southern Europe. Energy and Buildings 23 (1996) 251-256

# Integrating Renewable Energy into Buildings

## Electricity from photovoltaics and wind turbines

Integrating renewable energy into buildings should technically cover all aspects of solar energy, wind power and even biomass. For the purposes of architectural design, this chapter will focus on renewable energy devices that can be fixed to buildings. In particular photovoltaic (PVs) arrays and wind turbines.

Both of these types of devices produce electricity that can either reduce or totally displace the need for grid based electricity to be imported to a building. The electricity produced has the potential to be used for lighting, refrigeration, motors and other electrical equipment. When excess electricity is produced it can also be fed into the grid to supply other uses.

However, the amount of energy produced by these devices is small compared to the typical amounts of energy currently used by typical buildings. Therefore, before these devices are considered in building design, the energy consumption of a building should be reduced to a practical minimum. All relevant methods of reducing energy consumption discussed in the previous chapters should be implemented before PVs or wind turbines are considered.



Figure 11.1

### Roof mounted photovoltaic array

100m<sup>2</sup> of Photovoltaic panels with a peak capacity of 12.5kWp, providing an average of 8,200kWhrs of electrical energy per year.

Architects; Hugh Byrd Associates

### Photovoltaics

Photovoltaics (PVs) are a way in which solar energy can be directly converted into electricity within a solid-state device. In principle, they are the most ideal way of generating electricity since they use the most abundant source of energy on the planet (solar energy) and they are made of one of the most abundant materials on the planet (silicone).

The photovoltaic effect occurs when light falls on the PV cells. In very simple terms, the energy from a

## Integrating Renewable Energy into Buildings

photon hitting a PV releases electrons. PVs are not 'thermal' collectors. In fact their efficiencies drop when they get hot.

In several countries the costs of PV installations has been subsidised in order to promote cost-effective manufacturing, reduce Carbon emissions associated with electricity generation and provide energy security. The price of electricity from PVs is on the verge of competing with other forms of electricity in countries where there are no subsidies (including New Zealand) and it is a matter of time before they become widely adopted.

## Designing PVs into buildings.

As global energy supplies reach a peak in the second decade of the 21st century, the cost of energy will rise exponentially. During this time PVs will become cost effective. However, this does not mean that nothing should be done until they become cost effective. We are designing buildings now that will be standing not only when PVs are commercially viable but also when fossil fuels are so depleted that there will be few other alternatives that are safe, require little maintenance and produce relatively small amounts of CO<sub>2</sub>. Even if PVs are not integrated into buildings now, building should be designed with PVs in mind.



PV installations on social housing in the UK.

The introduction of a subsidy in the form of a 'Feed-in-tariff' has made PVs a common household electrical appliance.



The main issues to be considered are:

a) The integration into the building to maximise the output of electricity (performance). This includes the orientation, shading and location of PVs and the electrical demand of the building.

b) The integration into a building to minimise costs. This includes not only the initial cost but also the lifespan of PVs and their performance.

Integration of PVs into buildings to optimise their performance.

### Integrated vs. Independent

Building Integrated Photovoltaics (BIPV) may seem to be an architecturally slick solution of integrating a high-tech product into a prominent part of a building. It has also been claimed that the cost of BIPV can be partly offset by reduced building costs since PVs displace building fabric (roofs or curtain walling). However, there are several aspects of BIPV that make it unattractive:

i) PVs currently have anticipated life spans of about 25 years. This may improve, but it remains significantly less than the building it is integrated with which may last 3 or 4 times longer. The costs of installing and replacing a truly integrated and large element of the building fabric are prohibitive especially as it is extremely unlikely that the replacement products will be identical each time.

ii) The efficiency of PVs drops rapidly with higher temperatures. Integrating PV arrays into building fabric will usually restrict ventilation to the back of the array.

PVs are most economically installed and maintained in a building by being fixed onto, but independent to, the building envelope. For buildings designed with the intention of installing PVs in the future, this offers significant design freedom.

### Optimum orientation and tilt.

The optimum performance is achieved by facing all cells towards the sun throughout the day. This can be done by 'tracking' the sun using a pivot system so that the PVs follow the sun's movement. However, tracking systems and moving parts can be expensive and require maintenance. Fixed arrays at an appropriate angle will not significantly compromise the performance of the PVs. Figure 11.2 indicates the efficiencies of PV arrays at different orientations and inclinations in Auckland.

A further consideration is that the tilt of a PV array could also be adjusted for peak demand within the building. For example, a peak demand in the afternoon, due to air-conditioning load, may influence the tilt of the array towards the West.

The assumption above is that PVs need to be flat and on one plane. 'First generation' PVs were based on

## Integrating Renewable Energy into Buildings

crystalline technology requiring protection by glass that generally resulted in flat arrays. 'Second generation' PVs are based on 'thin film' technology that does not always require glass and can easily be curved.

The area of PVs required to meet an electrical demand of a building.

At present the efficiencies of commercial systems are approximately 10% although higher efficiencies have been achieved and, with further research, efficiencies

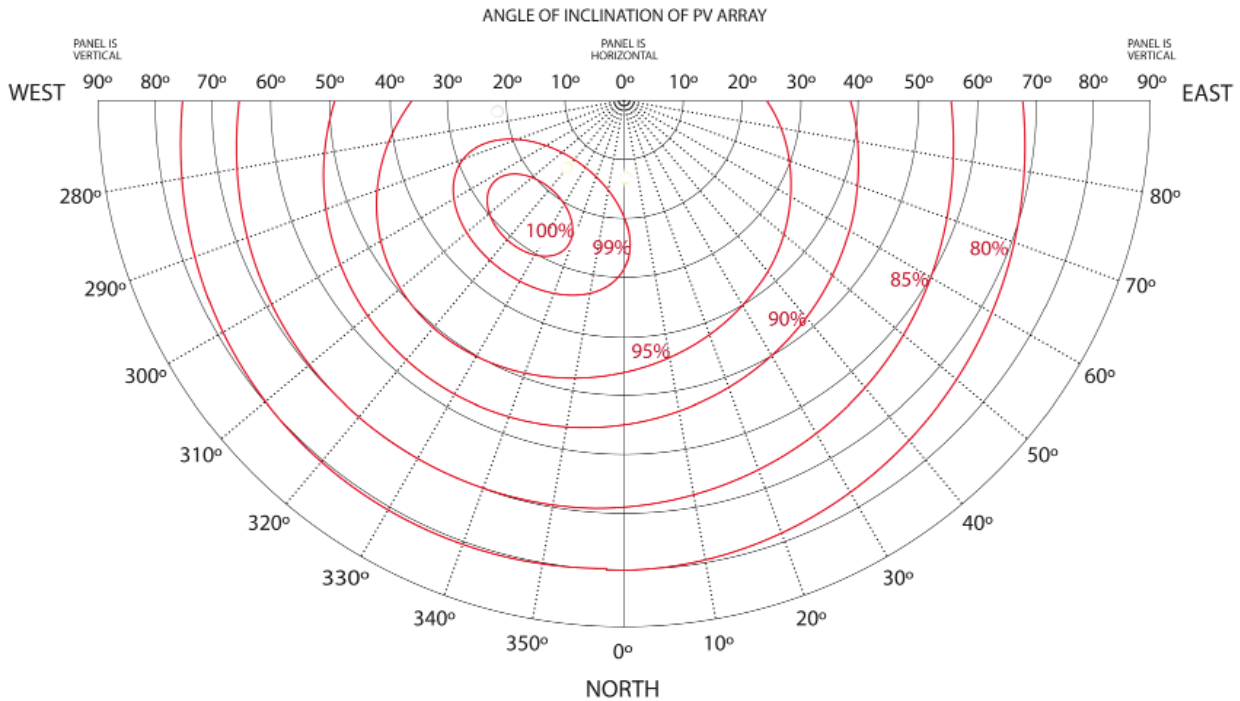

Copyright, Hugh Byrd

AUCKLAND SOLAR PANEL EFFICIENCY

Figure 11.2

### Minimum Efficiencies of PV Arrays According to Orientation and Inclination. (Auckland)

As a rule-of-thumb, there is very little difference in performance for arrays with an orientation within + or - 45° of Northwest and from almost flat to an inclination of 45°.

of 20-25% may be feasible. Trial tests on PVs (Refs 3 & 4) show that, at present, it is possible to obtain about 100-125 kWh per year for every square meter of photovoltaic array.

An energy efficient commercial building should be able to achieve an annual energy consumption of about 125 kWh/m<sup>2</sup>. In other words, 1 m<sup>2</sup> of PV array is required for every 1 m<sup>2</sup> of floor area (1:1 area). This is a useful rule-of-thumb that will need altering as efficiencies increase. For buildings that have a roof area the same as the floor area, it should, in theory, be almost net zero energy in electricity. However, supply and demand for electricity seldom matches for various reasons.

For example, additional electric lighting requirements at the beginning and end of every day, air-conditioning peak loads and problems with very cloudy days.

Although these make the system less efficient, the increased efficiencies of photovoltaics in the future will still result in the rule of '1:1 area' being a good starting point. Furthermore, the energy consumption of buildings can be reduced and low-energy commercial buildings can operate at about 50-70 kWh per year.

The amount of energy required for an average New Zealand house has been estimated by EECA and is illustrated in Figure 11.3. The assumption is that hot water will be heated by other means.

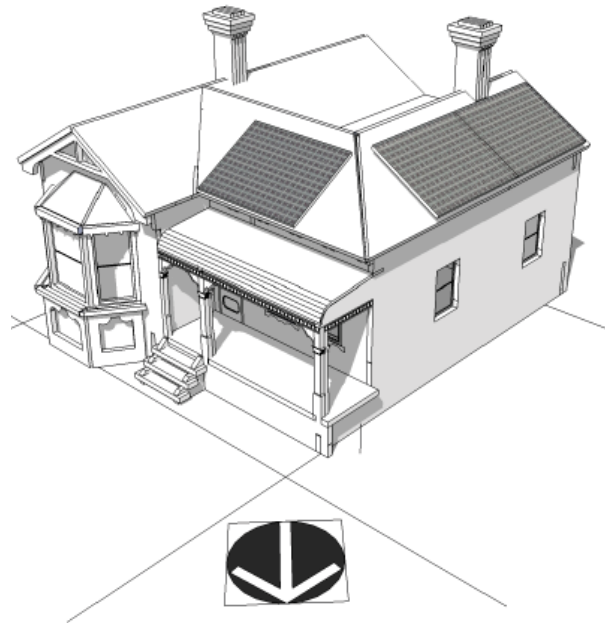

Figure 11.3  
Providing Enough Energy for NZ Houses

According to the New Zealand Energy Efficiency and Conservation Authority (EECA) (ref. 1), a typical household needs about 12kW (peak rating) of PVs to supply its annual electricity needs. This results in an area of PVs of about 16m<sup>2</sup>. This area is indicated on a typical villa. The orientation and inclination of the roofs results in an efficiency of between 95 to 100% (figure 11.2).

Ref. 1 <http://www.energywise.govt.nz/how-to-be-energy-efficient/generating-renewable-energy-at-home/solar-electricity-generation>

## Wind turbines

Although wind turbines are best suited to rural areas with a smooth flow of air, they can be installed on buildings provided there is limited turbulence from the surroundings and an adequate wind speed.

The electricity produced by a turbine can be roughly estimated from the following formula;

$$E = 3.2 \times V^3 \times A$$

Where

E is the annual energy production (KWh pa)

V is the mean site annual windspeed (m/s)

A is the area 'swept' by the turbine (m<sup>2</sup>)

The first thing to notice from this formula is that size counts. The 'swept area' is proportional to the square of the turbine radius. A turbine of 2m radius will produce 12 times as much energy as one of a 1m radius.

The second thing to notice is that energy produced is proportional to the cube of the site average wind speed. Although there are statistics of average wind speeds for cities in New Zealand, these should not be used for establishing the feasibility of wind turbines for a given site. However, as an illustration of the importance of wind speed on energy production, a comparison can be made between Christchurch and

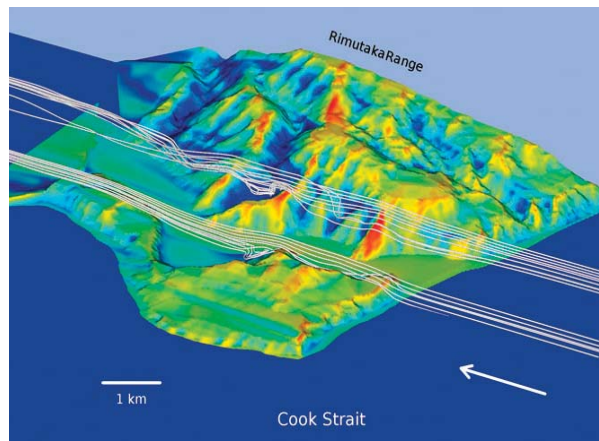

Figure 11.4  
Microscale Modelling of Wind Speeds in Wellington.

The model illustrates microscale modelling of wind speeds in Wellington. Red is high average wind speeds and dark blue represents low speeds.

<http://www.niwa.co.nz/news-and-publications/publications/all/wa/13-4/wind>

Wellington. The average annual wind speed in Wellington is approximately 7.2 m/s and that of Christchurch is 5.5 m/s. This apparently small difference in wind speed results in a potential of more than twice as much wind energy being available in Wellington.

Figure 11.4 illustrates the importance of not generalising about wind speeds. The feasibility of a wind turbine will depend on its local microclimate and not average wind speeds for the general area.

## Types of wind turbine.

For the practical use on buildings, wind turbines fall into two categories:

- a) horizontal axis wind turbines (HAWTs) and
- b) vertical axis wind turbines (VAWTs).

HAWTs tend to be more efficient in smooth flowing winds and hence their predominance on wind farms. However, in urban areas VAWTs have other benefits that include less noise and better performance in turbulence.

VAWTs do not need gears and the tip of the blades move slower than HAWTs. Both of these factors are the main contributors to noise. They also do not need to track the wind so they are always producing peak power at any given wind speed and direction.

Figure 11.5 illustrates some VAWTs of different sizes that have been used in an urban environment and their typical energy production is indicated.

For an energy efficient building averaging an electrical consumption of 75KWh pa, one qr5 turbine will service about 100m<sup>2</sup> of floor area.

It should be noted that manufacturers quote the output of a wind turbine based on a 'capacity' rating

of a high wind speed. Actual generating rates are lower and a rule-of-thumb is that actual generating rates are 25% of the capacity rating.

There are HAWTs that are suitable in an urban environment. Figure 11.6 illustrates a turbine that has protection around the tips of the blades. The purpose of this is to reduce noise.

## The Problem of Storing Surplus Energy

The problem with renewable energy from PVs or wind turbines is that the electricity is not always produced at the time that you need it and is often produced at times when it is not required. In order to make these devices cost-effective, they need to be able to maximise the use of the energy generated.

To overcome this, some form of a storage system is required in order to avoid wasting the energy being produced at unwanted times or to be able to draw upon the store when there is an inadequate supply of electricity from the devices at times of greatest use.

Traditionally and especially in small installations, a battery of some form would chemically store the energy. Battery technology on a large scale has problems of cost, physical space required and the life-cycle of the chemicals. Apart from buildings in remote areas, it is

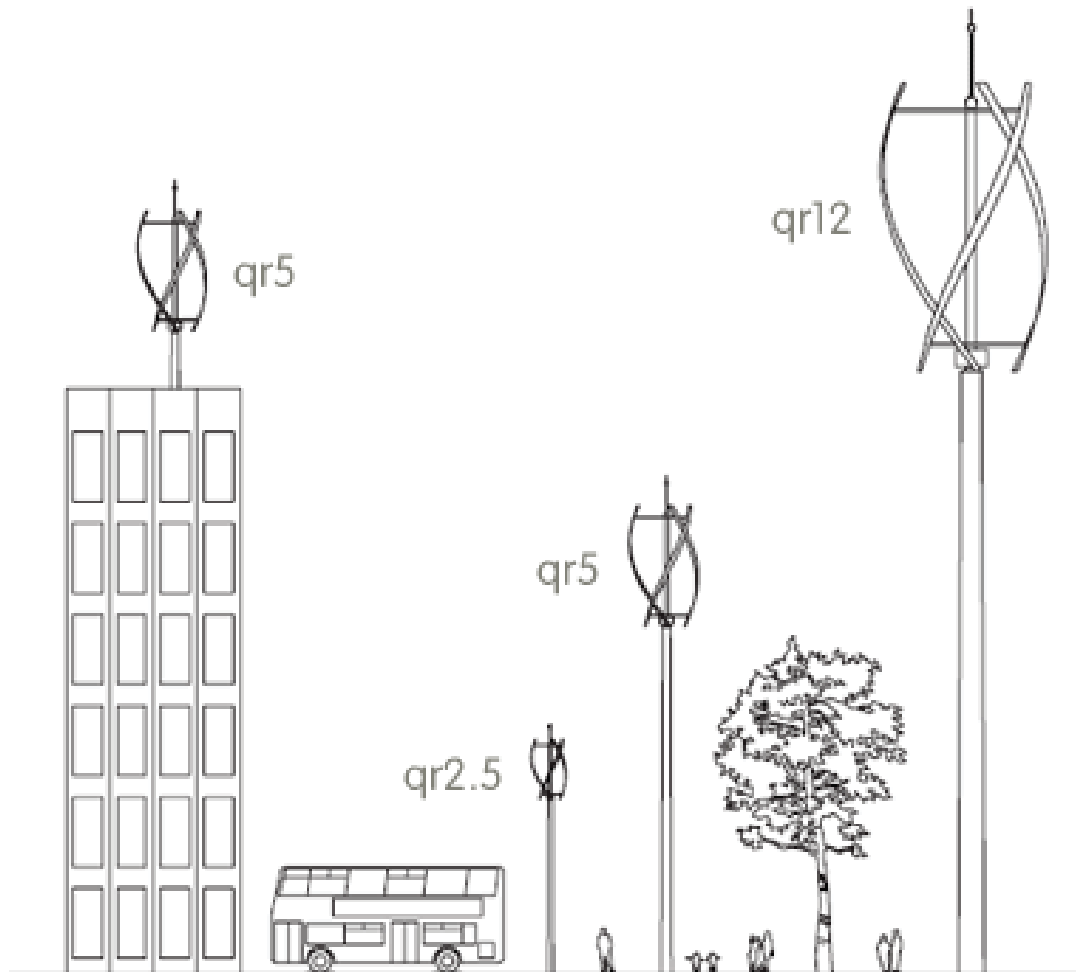

Figure 11.5  
Vertical Axis Wind Turbines commonly used in urban areas.

qr 12 has a typical output of between 45,000 and 55,000 KWh pa.  
qr 5 has a typical output of 7,500 KWh pa  
qr 2.5 has a typical output of 3 to 4,500 KWh pa.



Figure 11.6  
HAWTs mounted on a tower on a building.

Two 1.5kW Swift wind turbines mounted on a feature mast structure at the front of the building providing approximately 8,000kWh of electrical energy per year. This energy was used for all the building's mechanical equipment. The tower was designed to accommodate further wind turbines in the future. Architects; Hugh Byrd Associates

not a practical method of storing energy for buildings at present.

If renewable energy is to be adopted on a wide scale, some form of storage device is required. There are various options in different stages of development.

1) Converting the electricity to Hydrogen. This is a simple process of the hydrolysis of water breaking it down into Oxygen and Hydrogen. The production of Hydrogen has further implications on the design of buildings. If Hydrogen is to be generated 'on site', then suitable storage is required. Hydrogen has a very high amount of energy per unit mass (about 3 times more energy than petrol). However, it has a very low amount of energy per unit volume (about 1/4 that of natural gas). It is uneconomical to cool it to a liquid form since this occurs at  $-253^{\circ}\text{C}$ . Therefore, large volumes are required for storing it. Buildings that are designed to be nearly self-sufficient from solar energy will, in the future, need to consider the storage of hydrogen.

2) The electricity could be diverted to recharging electric vehicles. This is particularly appropriate for wind turbines that carry on producing energy throughout the night when electricity use is at its lowest.

3) The energy could be used for pumping water back up into lakes as potential energy for hydro-electric

## Integrating Renewable Energy into Buildings

plants.

4) Using the energy to cool thermal stores in or near buildings in order to reduce the cooling load of a building.

5) Feed the electricity back into the grid for other users.

### Smart Grids and Smart Metering

All these options of storage are feasible but there is no easy or commonly available method of being able to select the optimum choice of when and whether to consume or store the energy and, if it is to be stored, where it should be channelled.

Smart grids and smart metering offer such a mechanism and have the potential to make renewable energy more economically viable.

Smart meters are capable of two-way communication so they can be optimised to either supply the building or the grid depending on tariff, load and energy generated by a renewable device.

They can also communicate with household appliances to automatically turn them off, or turn them down during times of peak electrical demand.

For example, electricity from PVs on a house can be diverted by a smart meter to either charge an electric vehicle (EV), be used within a house or be sold to the

grid.

If an EV is fully charged it can be used to sell electricity to the grid or be used by the house in the event of a grid blackout. The combination of renewable energy technologies combined with smart metering and EVs provides an opportunity for resilient buildings.

### References

EECA. Solar Electricity Generation: Photovoltaics. <http://www.energywise.govt.nz/how-to-be-energy-efficient/generating-renewable-energy-at-home/solar-electricity-generation>.

NIWA. Wind and Wind Energy. <http://www.niwa.co.nz/news-and-publications/publications/all/wa/13-4/wind>

Boyle, G. (2004) *Renewable Energy: Power for a Sustainable Future*. Oxford University Press. Oxford.



# Designing for Tropical Climates

The general principles of cooling, lighting and ventilation described previously also apply to tropical climates. However, there are some significant differences. The main characteristics of a tropical climate are the heat and the humidity. Modern buildings resort to air-conditioning but, until electricity arrived, buildings were designed that responded to the climate and provided comfortable temperatures using passive methods.

## Implications of solar geometry

In tropical climates the sun rises in the East, passes almost directly overhead and sets in the West. This results in vertical surfaces facing East and West being exposed to direct solar radiation at the beginning and end of each day and roofs being exposed throughout the middle of the day. Unlike temperate climates, there is no beneficial solar heat gain in buildings in the tropics. Ideally, every part of a building, walls, windows and roof, need to be protected from the sun. The importance of shading on each of these elements depends on the form and purpose of the building. For example, a high-rise building will have a relatively small amount of energy entering the roof while, in the case of a single storey building, the roof could act as the complete shading device for the whole building.

Although most solar energy entering a building will pass through openings, solid walls exposed to the sun will conduct and radiate energy to the inside of buildings. To increase comfort and reduce cooling loads walls should be shaded where practical. To maximise shading on walls there are several guiding principles that should be adopted when designing a building.

a) Minimize the area of a building facing East and West and orientate a building so that most fenestration faces South and North. The conventional optimum shape is a rectangular block with its short sides facing east/west. Alternative types such as the 'atrium' or the 're-entrant' plan forms (Hyde 2000) allow glazing to the north/south orientation and a more compact plan. These plan forms allow for daylighting to penetrate into all working areas while, at the same time, excluding direct solar gain from East and West orientations. There are many permutations to these 3 generic plan types that can be manipulated to accommodate the shape of most sites.

b) Locate 'core' spaces (spaces less vulnerable to overheating; circulation space, toilets etc) on the East and West elevations. Warmer temperatures can be tolerated in these spaces so they can act as a buffer to the thermally sensitive spaces.

c) Walls facing East or West should be reflec-

## Designing for Tropical Climates

tive in colour and preferably insulated. Colour has a profound effect on the heat absorbed by the fabric of a building. Givoni (1994) carried out research on the affect of colour on the external face of a concrete wall. The rooms where the walls were painted white, closely followed the external temperature while the bare concrete walls exceeded the internal temperature by about 70°C. Insulating the walls further reduces heat gain.

### Shading devices

Internal shading devices such as blinds are of little benefit. Although they can be useful to reduce glare, much of the solar energy absorbed by them is re-radiated into the room.

External louvers should minimise the amount of daylight they obstruct. External louvers or canopies should be lightweight. Heavyweight canopies store heat during the day and re-radiate it at night. This reduces the ability of the building to cool.

Even south and north facing glazing requires protection from the sun since its position varies throughout the year. Windows should either be recessed or vertical fins fixed to either side of windows.

Neither horizontal nor vertical fixed fins, nor a combination, will provide complete shading to windows facing east or west without also completely obscuring the aperture (Givoni 1994 p29). This will significantly reduce daylight penetration and make the window

almost redundant in an air-conditioned building. However, East and West elevations could benefit from moveable shading systems if there is no alternative location for the glazing.

### Openings for natural ventilation

In hot-humid climates naturally ventilated buildings require not only cross ventilation but also supplementary air movement to achieve comfort levels. Provided there is no direct penetration of solar radiation, thermal comfort can be achieved with air speeds of about 2.0m/s.

Apertures need to be completely protected from the sun while any form of shading should not restrict airflow. Traditionally, large overhangs or canopies have achieved this with apertures on opposite sides of the room. For example, in schools (Powell 2001), openings in walls should be equivalent to at least 20% of the floor area assuming fans are provided (1 per 15m<sup>2</sup> floor area).

### Ventilating under the roof.

Depending on the efficiency of the roof materials, all roofs will re-radiate heat to the inside of a building. Provided there is a further barrier between the roof and the room beneath, the heat can be removed by ventilation. There are two techniques to achieve this:

a) By putting another roof on top of the first roof to form a 'shading' roof that is separate from the water-proofing roof. The problem with this technique is that two roofs can be uneconomical. However, if the shading roof has another purpose (for example, photovoltaic cells) it can both shade and generate electricity at the same time.

b) Alternatively, if there is a ceiling under the roof, then the roof void can be ventilated. Research (NERU 1998) has been undertaken on the effect of ventilation in insulated roof voids and indicates that rapid ventilation (50 air changes per hour) can reduce the cooling load by about 10% to 20% compared with ventilation of 10 air changes per hour.

### PVs in tropical climates

Other than PVs that can track the sun, the optimum position for PVs is horizontal (Figure 12.1). However, the performance of the PVs could be significantly affected if they are not regularly cleaned. Alternatively, a pitch of 10° results in rain washing the surface. Although tropical countries have a high amount of diffuse solar radiation, resulting in indirect solar radiation on vertical surfaces, locating PV arrays on vertical surfaces will reduce their performance.

A further consideration is that the tilt of a PV array could also be adjusted for peak demand within the building. For example, a peak demand in the afternoon,

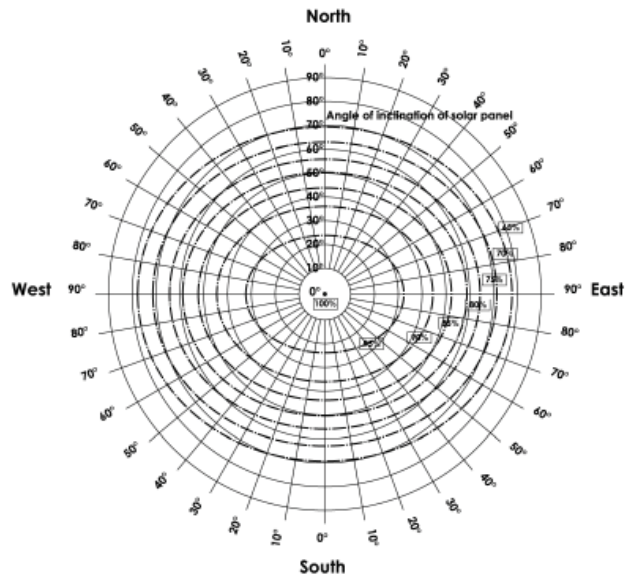

Figure 12.1  
Optimum tilt and orientation for PVs in tropical climates.

due to air conditioning load, may influence the tilt of the array towards the west.

### References.

- Givoni, B (1994), *Passive and Low Energy Cooling of Buildings*. International Thompson Publishing Inc.
- Powell, R (2001), *Architecture of Learning*. Akimedia Pte Ltd p49
- Hyde, R (2000). *Climate Responsive Design*. Spon Press
- National Energy Research Unit (1998), *Roof Insulation Saves Cooling Energy*. Research Bulletin, Solarch, University of New South Wales, Sydney.

